

Assembly Instructions

Before assembly

- We recommend that time is taken to read the instructions before starting assembly, then follow the easy step by step guide. The instruction sheet is only a guide to the assembly. Certain items may not be shown to scale.
- This product should be assembled by no less than 2 people.
- Never attempt to erect the assembly in high winds.
- Drill components where indicated.



Recommended tools for assembly

- Cross head screw driver
- Hammer
- Drill
- 3mm diameter drill bit
- 10mm diameter drill bit
- 13mm spanner
- Step ladder

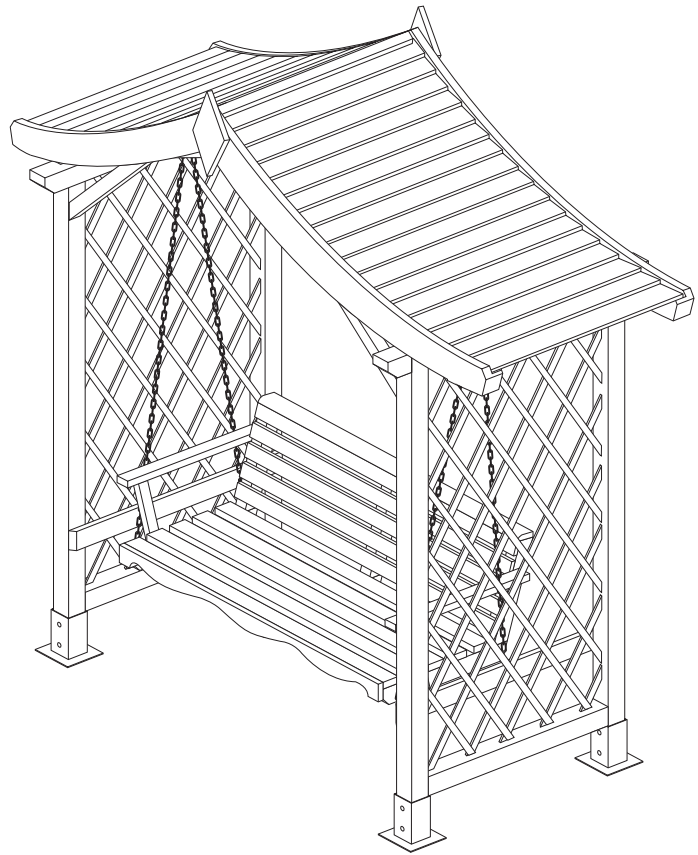

No.	Components	Qty.
1	Bench back	1
2	Bench seat with shaped front rail	1
3	Bench arm left	1
4	Bench arm right	1
5	Uprights	2
6	Top rail	1
7	Front right/back left angled braces	2
8	Front left/back right angled braces	2
9	Corner supports	4
10	Roof sections	2
11	Coverstrip	1
12	Metal post stands	4
13	Chain support brackets	2
14	Chains	2
15	Finials	2

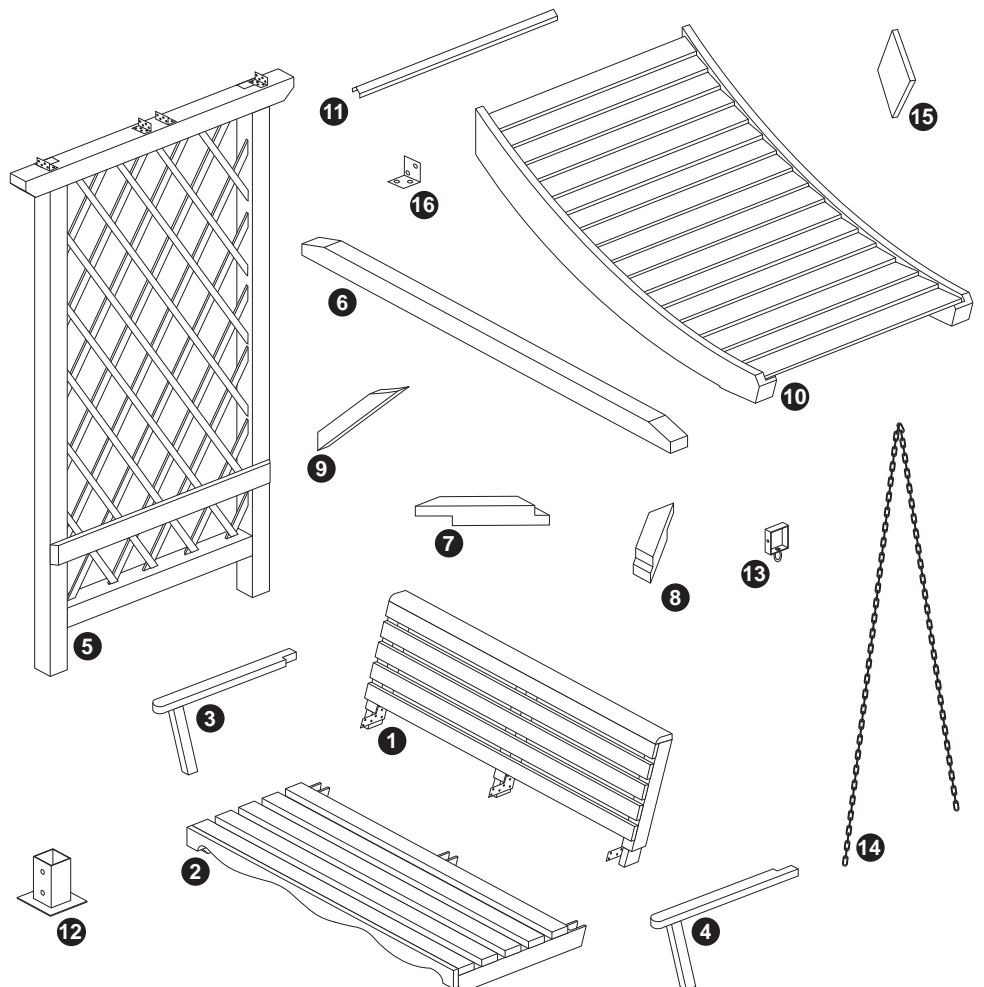

No.	Fixing kit	Qty.
16	Metal L-brackets	2
	90mm bolts	8
	washers	8
	Nuts	8
	60mm screws	40
	3.5 dia. x 40mm screws	67
	6 dia. x 40mm screws	2

1. Metal post stands

Slot a metal post stand on to the bottom of each leg of the 2 uprights, ensure the upright legs go all the way to the bottom of the metal stands. Using a 10mm drill bit, drill 2 holes in each upright leg using the holes in the metal post stands as guides. Insert a 90mm bolt through each hole, to the threaded end add a washer followed by a nut. Tighten the nut using a 13mm spanner.

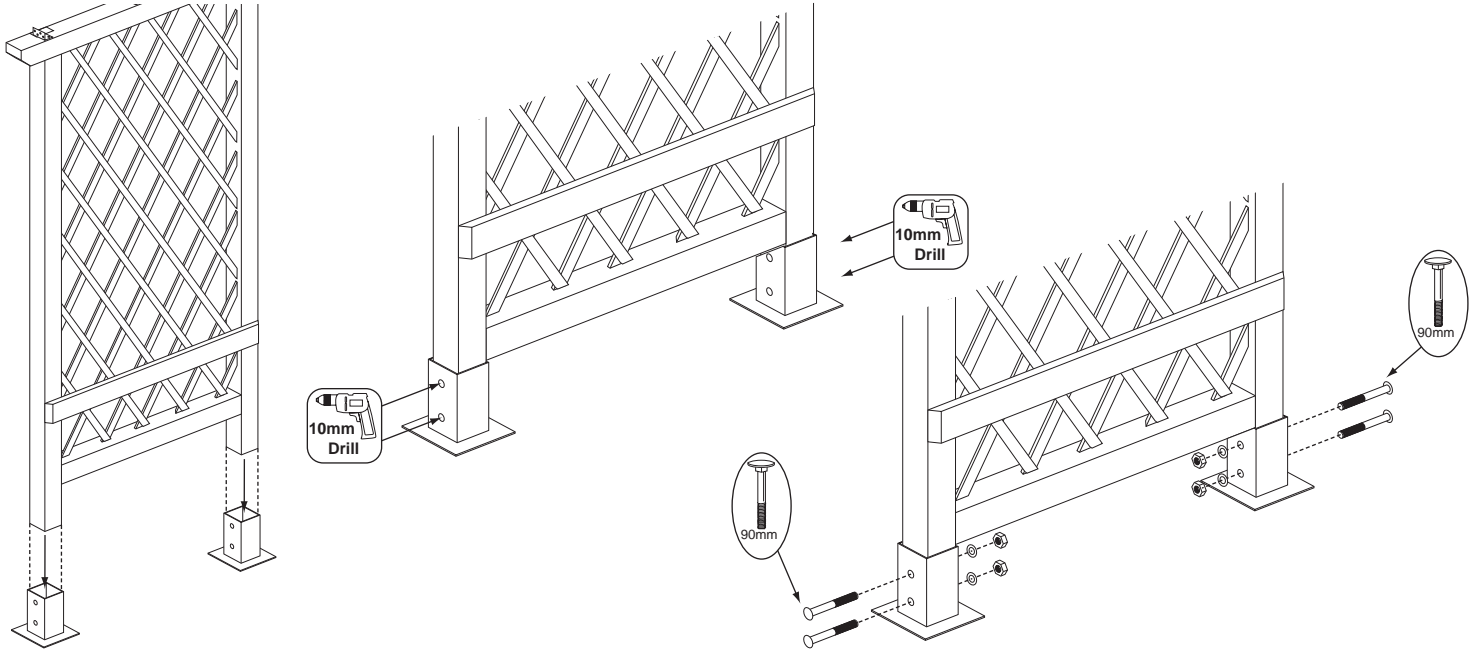

2. Top rail

Onto each end of the top rail slide a chain support bracket. position the top rail on the top of the 2 uprights between the pre-fitted centre metal I-brackets. have the the ends of the top rail flush to the outside edge of the upright. Secure the top rail in place using 4 x 40mm screws per bracket.

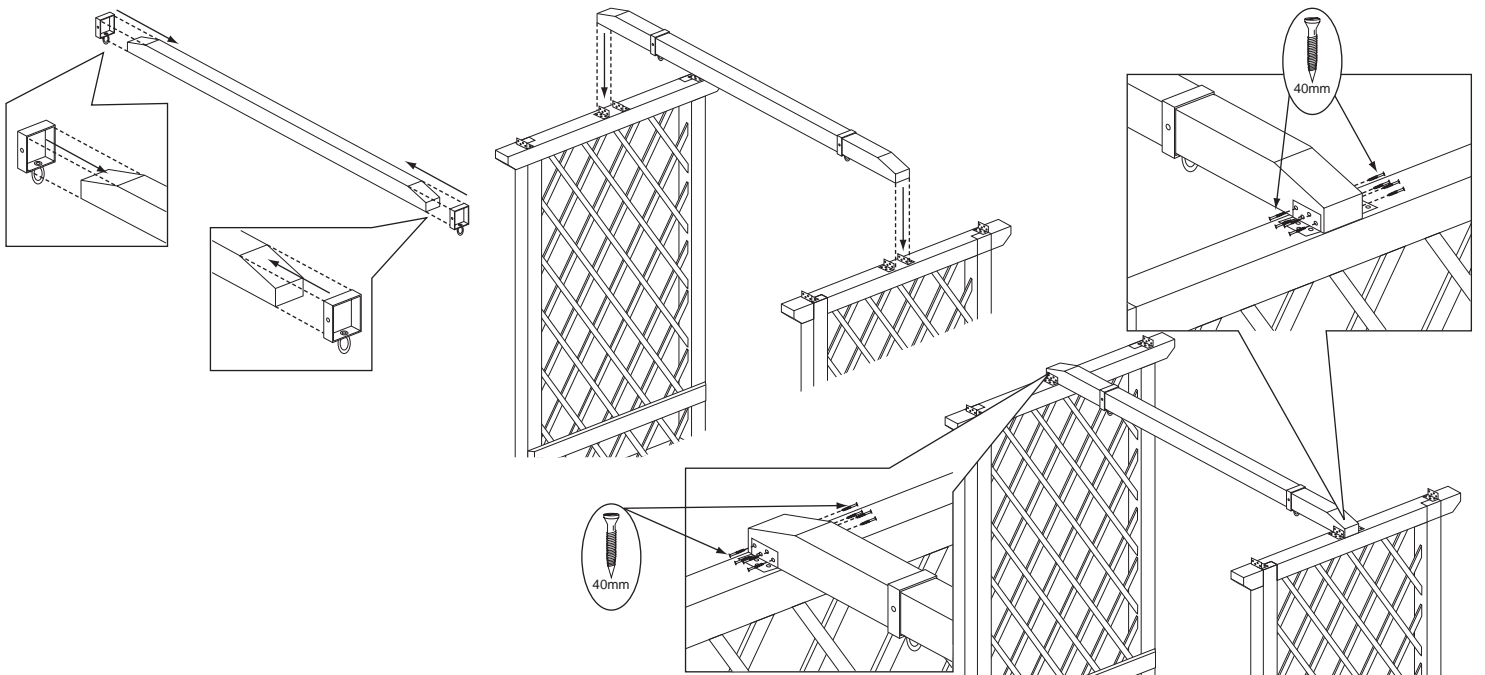

3. Secure chain support brackets

For the position of the chain support brackets, measure from the inside edge of the upright 40mm, position the chain support and fix in place using 1 x 6mm dia. x 40mm screw per support bracket.

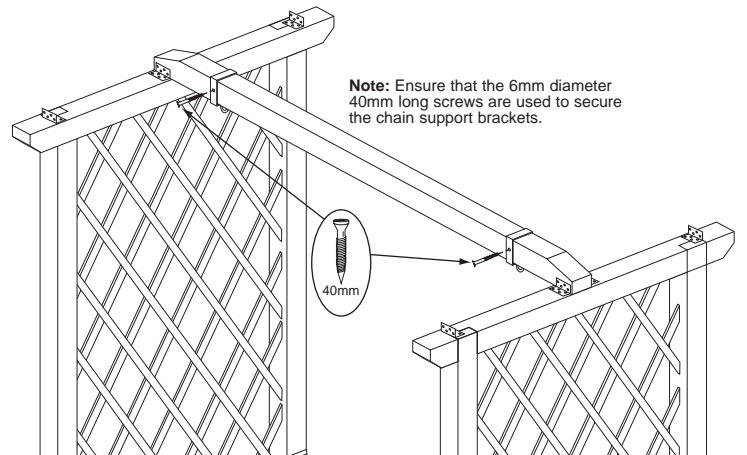
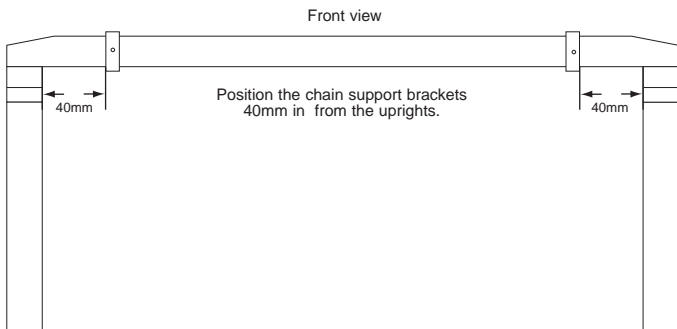

4. Angled braces

For each angled brace drill 4 holes in the end with the large rebate and 2 holes in the end with the short rebate as shown below. Position each brace so that the large rebate sits on top of the upright and the small rebate is under the top rail. Secure the braces in place using 6 x 60mm screws per brace.

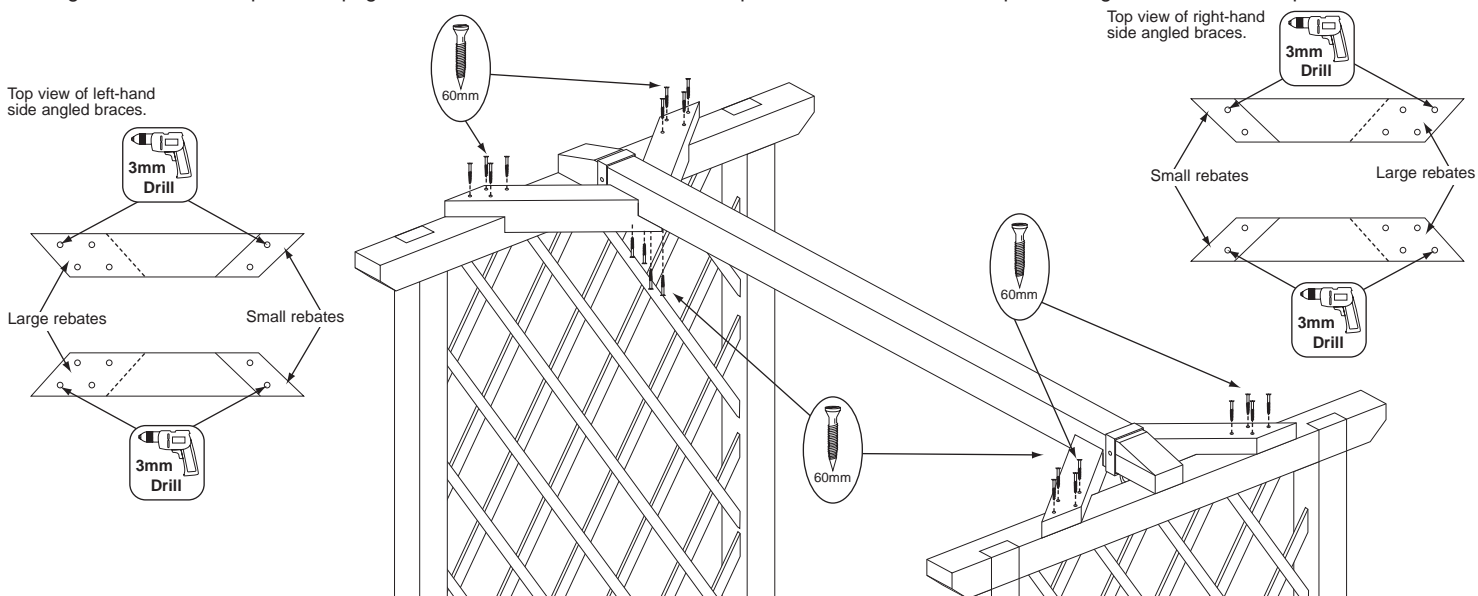

5. Roof sections

On a roof section attach an L-bracket to the underside of each roof bearer at the apex end using 2 x 40mm screws per bracket. Evenly rest the second roof section against the first and attach using 2 x 40mm screws through the L-brackets. Drill 4 holes in each finial. Centre the finial so it overlaps both roof rafters and secure using 4 x 40mm screws per finial. Drill 2 holes at each end of the cover strip and secure on the roof ridge using 4 x 40mm screws.

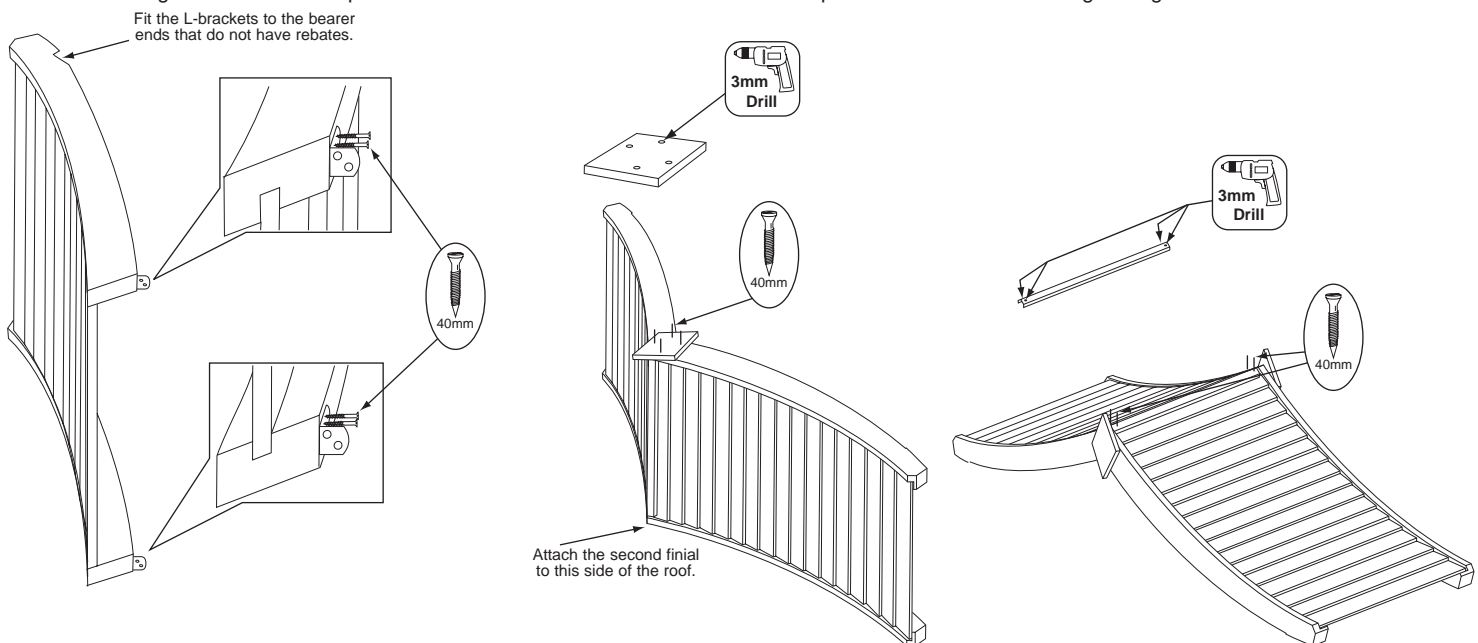

6. Roof

Lift the assembled roof onto the uprights having the pre-fitted metal L-brackets on the uprights inside of the roof. Ensure the rebates in the roof rafters rest on the uprights and secure the roof to the uprights using 4 x 40mm screws per metal L-bracket.

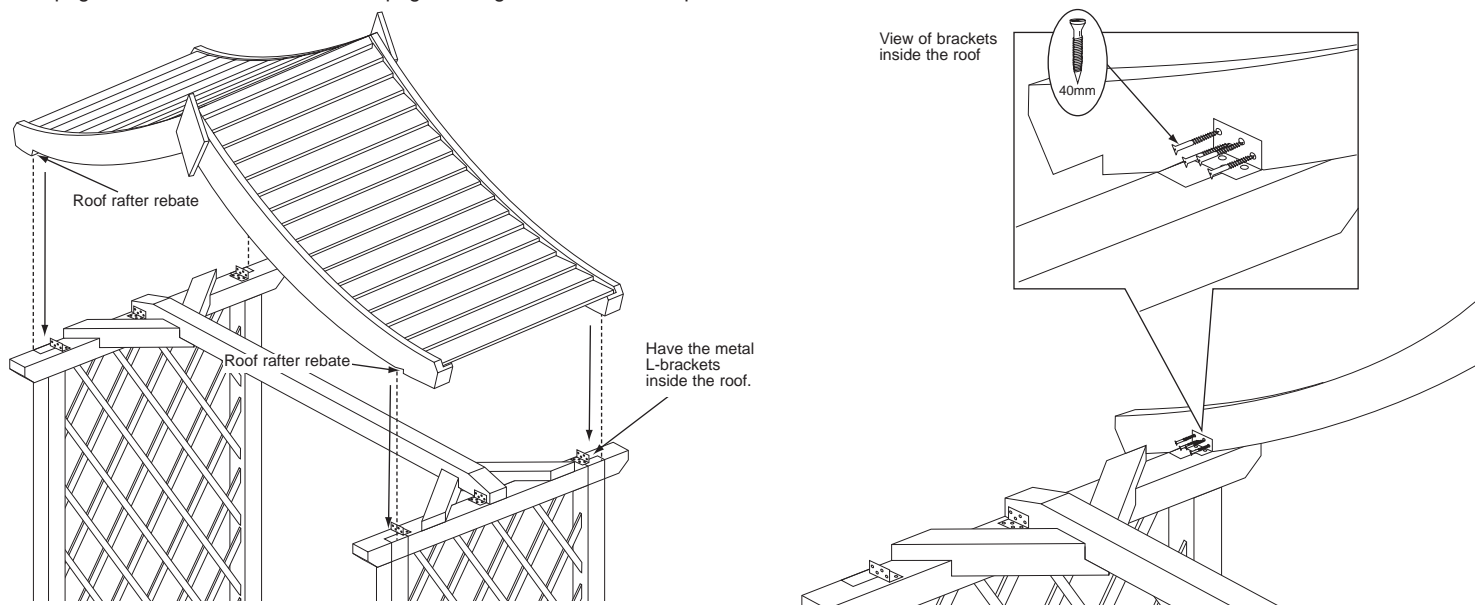

7. Corner supports

Drill a hole in each end of the corner supports as shown and secure 1 between each upright leg and a roof rafter using 2 x 60mm screws per support.

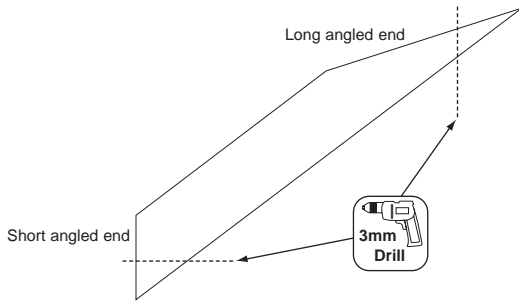

Note: Have the long angled ends to the roof rafters and the short angled ends to the uprights

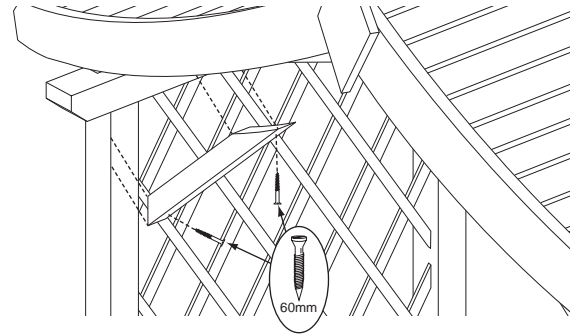

8. Bench assembly

Slot the bench back into the rebates at the back of the bench seat (Note: the bench seat has a shaped front rail), ensure they are located fully and secure in place using 5 x 40mm screws for each of the 3 metal brackets. Drill the holes in the arm rest as shown and secure to the side of the bench using 4 x 60mm screws per arm rest.

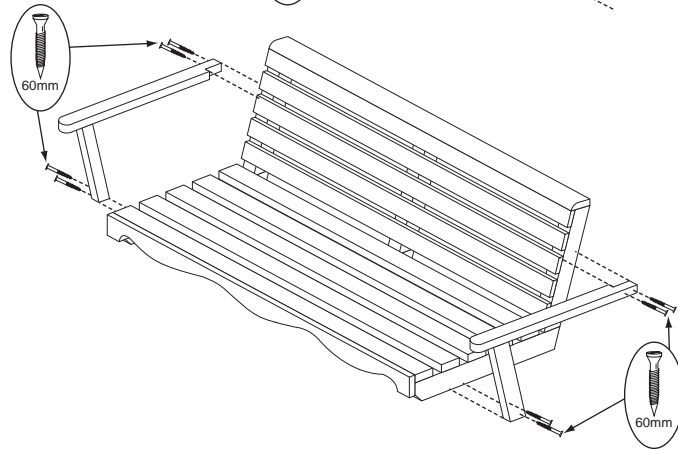
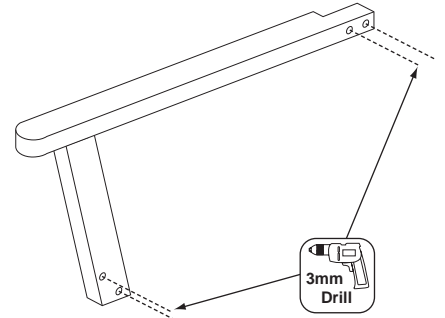
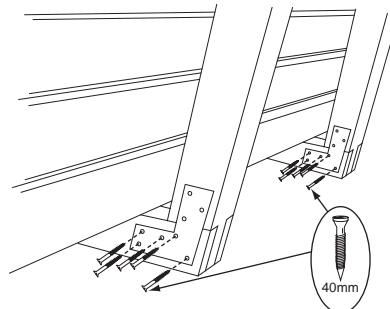
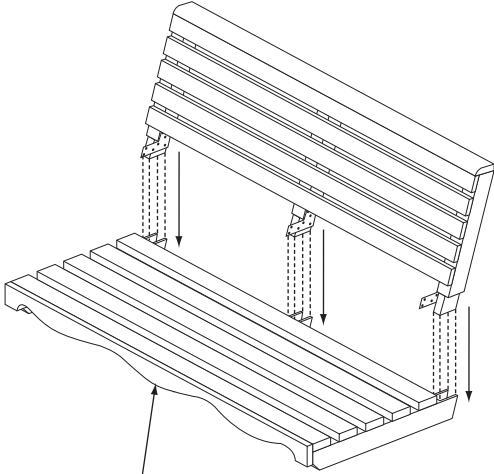

Important note:
Component identification. The bench seat section has a shaped front rail where as the bench back does not.

9. hanging the bench

Find the middle link of each chain and hook 1 on each clip of the chain support brackets. If the link is difficult to connect, gently tap the link on a solid surface with a hammer to expand. Lift the bench up and hook the ends of the chains to the hooks on the sides of the bench.

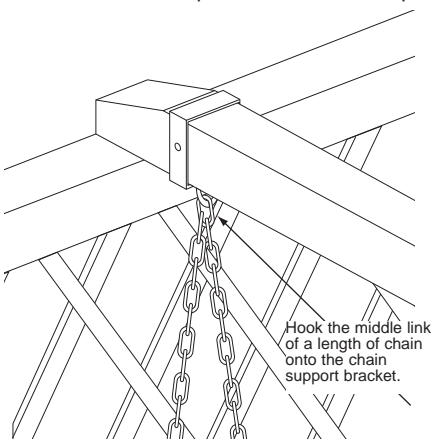

If the link is too small, tap the link gently with a hammer to expand

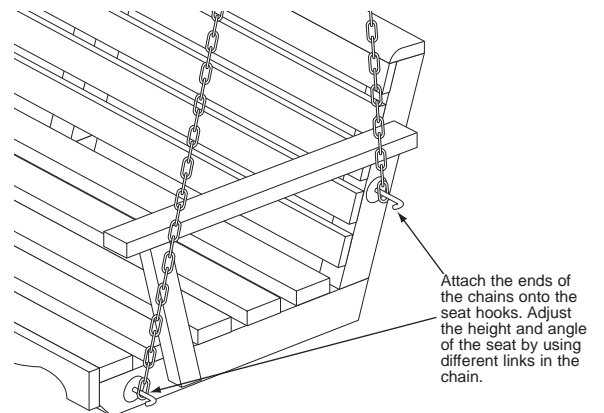
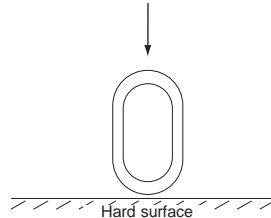

Attach the ends of the chains onto the seat hooks. Adjust the height and angle of the seat by using different links in the chain.

If in doubt of any aspect regarding the assembly, use or safety of your building please contact us :

Help Line (Normal Office Hours) 01270 506900

ROWLINSON GARDEN PRODUCTS LIMITED
Weston Road
Crewe
Cheshire
CW1 6FZ
Tel : +44 (0)1270 506 900
Fax : +44 (0)1270 506 909

We constantly improve the quality of our products, occasionally the components may differ from the components shown and are only correct at time of printing. We reserve the right to change the specification of our products without prior notice.

2003 © Rowlinson Garden Products