

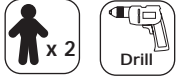

**Before assembly**

- We recommend that time is taken to read the instructions before starting assembly, then follow the easy step by step guide. The instruction sheet is only a guide to the assembly. Certain items may not be shown to scale.
- Check all components prior to assembly
- This product should be assembled by no less than 2 people.
- Never attempt to erect the assembly in high winds.
- Drill components where indicated.



**Recommended tools for assembly**

- Cross head screw driver
- Drill with 4mm diameter drill bit
- Tape measure
- Step ladder

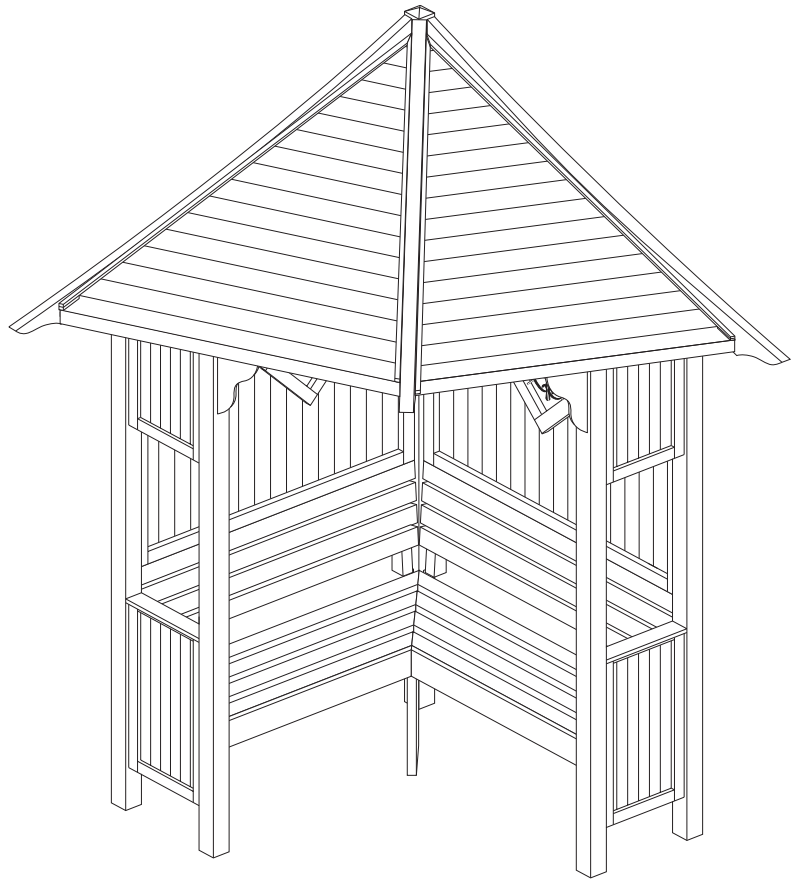

No.	Components	Qty.
1	Seat back	2
2	Seat leg	2
3	Left-hand seat	1
4	Right-hand seat	1
5	Left-hand seat fascia rail	1
6	Right-hand seat fascia rail	1
7	Left-hand upright	1
8	Right-hand upright	1
9	Centre post	1
10	Centre roof rafter support	1
11	Back lattice panel	2
12	Left-hand roof rafter	1
13	Right-hand roof rafter	1
14	Centre roof rafter	1
15	Roof panel	2
16	Front coverstrip	2
17	Left-hand top coverstrip	2
18	Right-hand top coverstrip	2
19	Left finial	1
20	Right finial	1

No.	Fixing kit	Qty.
21	40mm screws	32
22	60mm screws	20
23	70mm screws	36
24	130mm screws	5
25	150mm screws	2

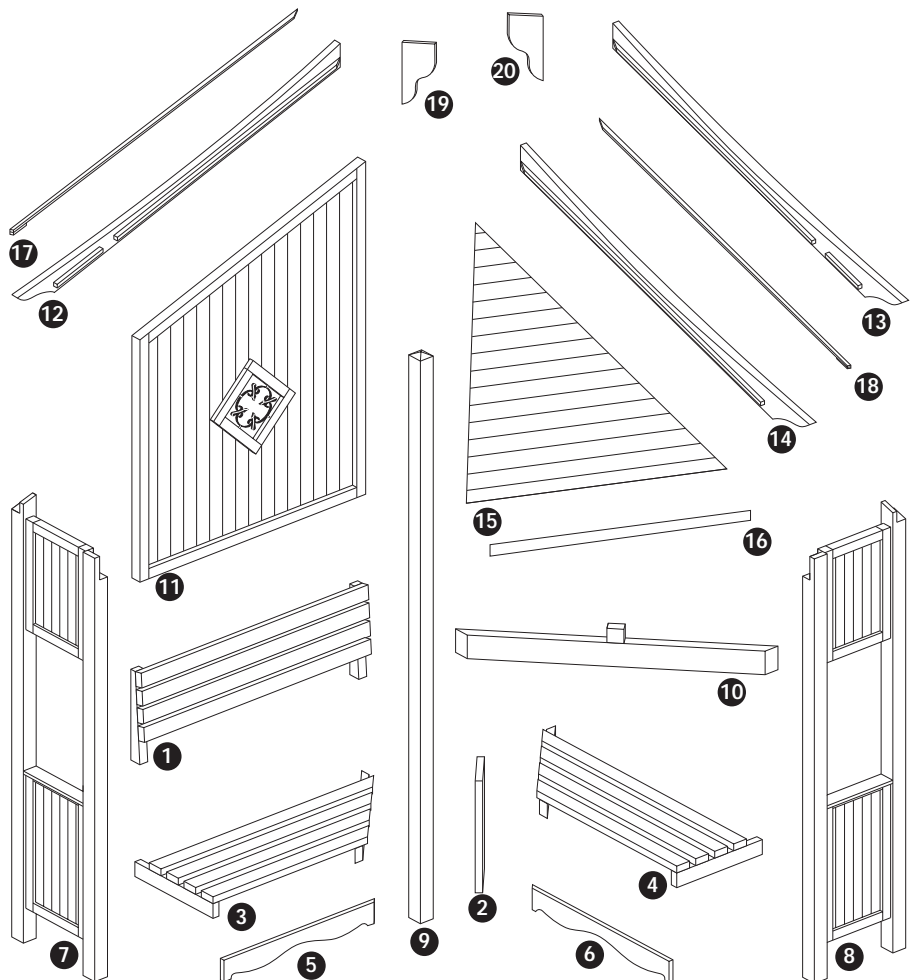

### 1. Back lattice panels to uprights

Using 2 x 70mm screws, fix the shorter side of a back panel to the left upright, ensure that the top of the back panel is aligned with the bottom of the angled rebate of the upright. Create a second upright and back panel section using the right-hand upright and a second back panel.

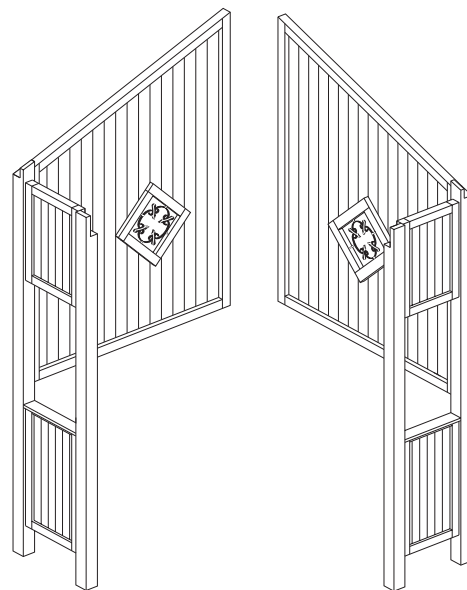
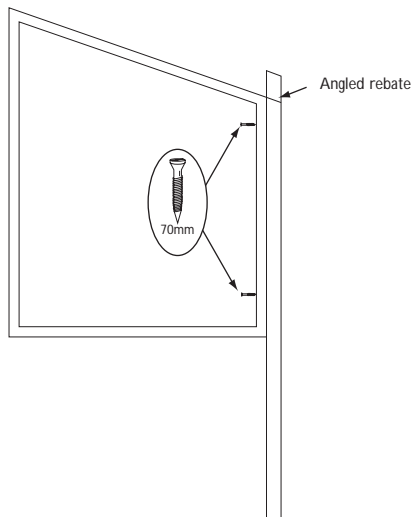

### 2. Seat backs to uprights

At each end of the 2 seat backs drill 2 holes in seat back frame as shown in the diagram. Position the seat back below the back panel, ensuring the seat back frame is flush with the back of the back panel, screw through the drilled holes in the seat back frame into the upright using 2 x 70mm screws. Repeat for the other upright section.

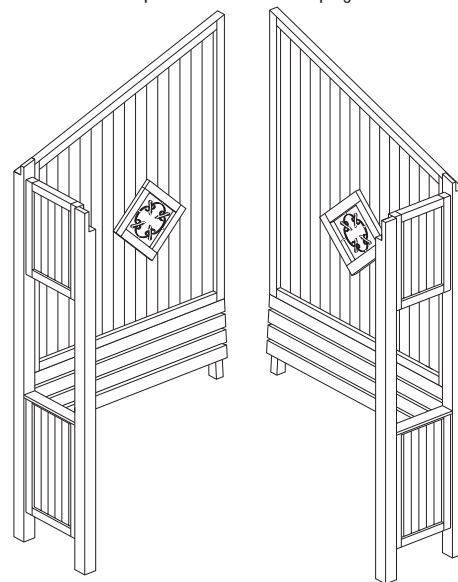
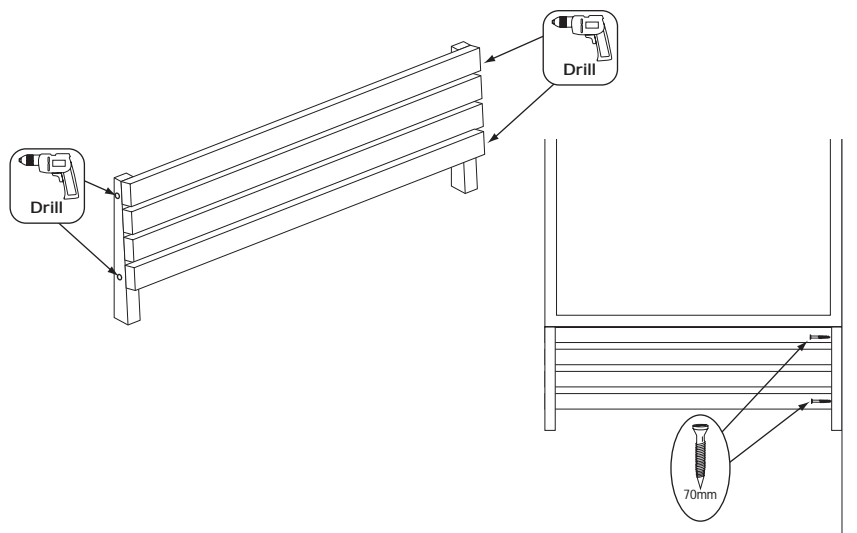

### 3. Seats to uprights

Before fitting the seats to the upright sections, fit a seat leg to the angled end of each seat using 4 x 70mm screws per leg as shown below. Attach the seat fascia rails to the front of the seats using 3 x 40mm screws per fascia. Drill holes in the seat bearers as shown below. Position the seat below the seat back, 360mm from the bottom of the upright, screw through the seats drilled holes into the upright using 4 x 70mm screws. Attach the second seat in the same way to the other upright section.

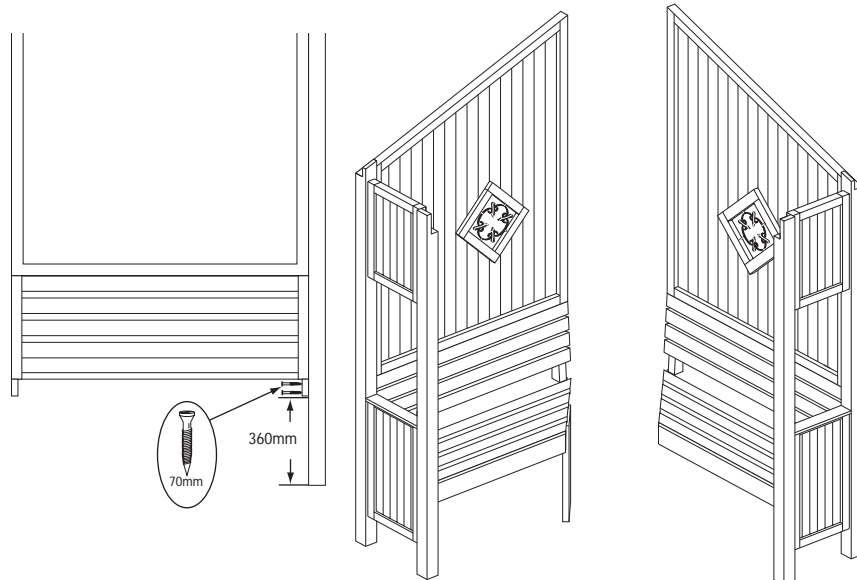
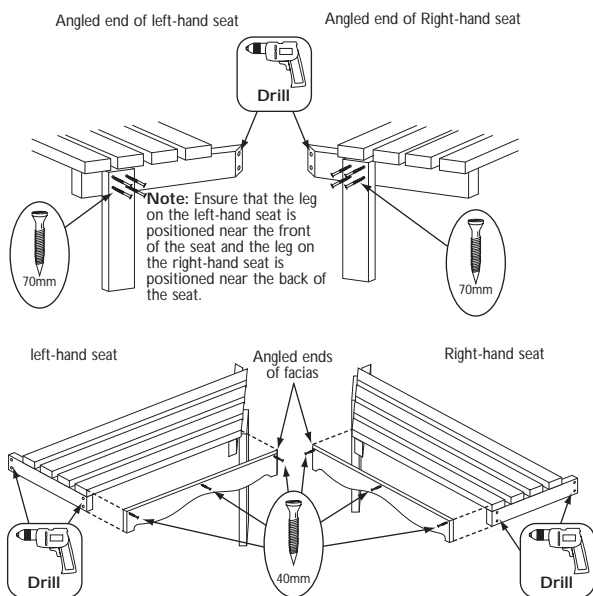

#### 4. Securing the centre post

Fix the centre post to 1 upright section, note orientation of drilled holes at the top of the post see diagram below. So that the seat is level make sure the post measurement below the seat is 360mm. Secure using 2 x 70mm screws through the drilled holes in the seat back frame and 2 x 70mm screws through the seat bearer. Fit the other upright section to the centre post in the same way.

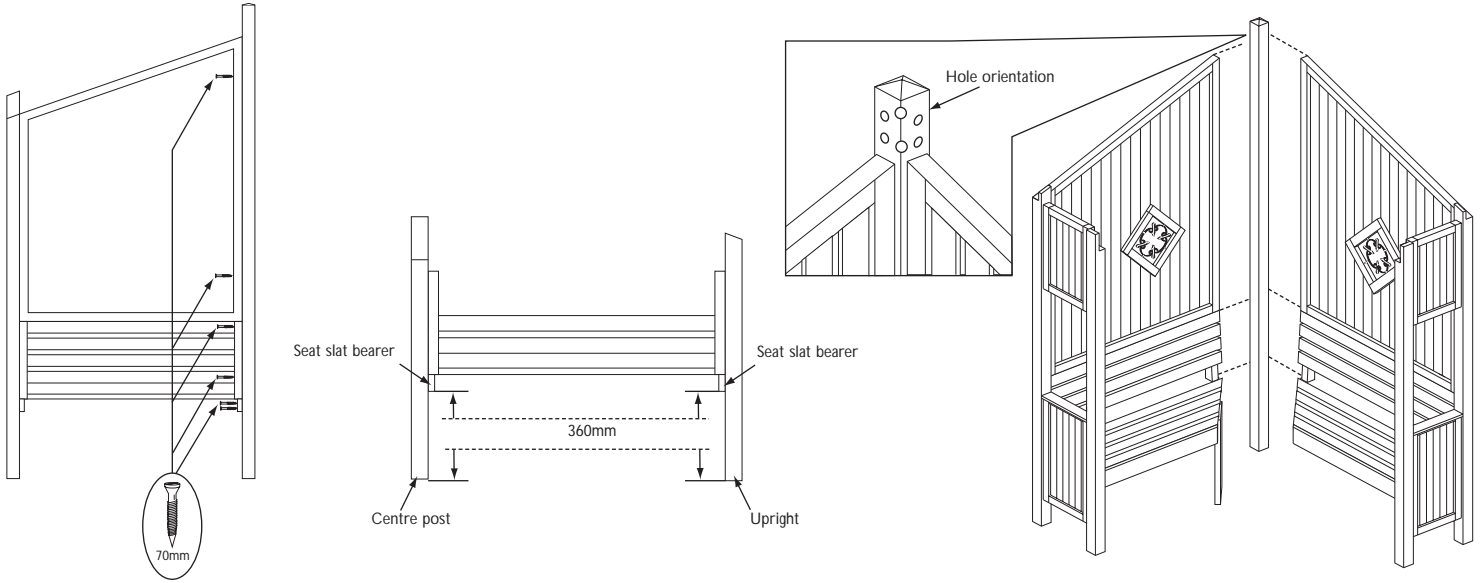

#### 5. Centre roof rafter support

Drill 2 holes in each upright panel where indicated in the diagram below. Sit the centre support in the rebates of the 2 uprights and secure using 4 x 60mm screws, through the drilled holes and into the centre roof rafter support. Drill 2 holes in each finial where indicated in the diagram. Fit the finials as shown using 2 x 40mm screws per finial to the centre roof rafter support.

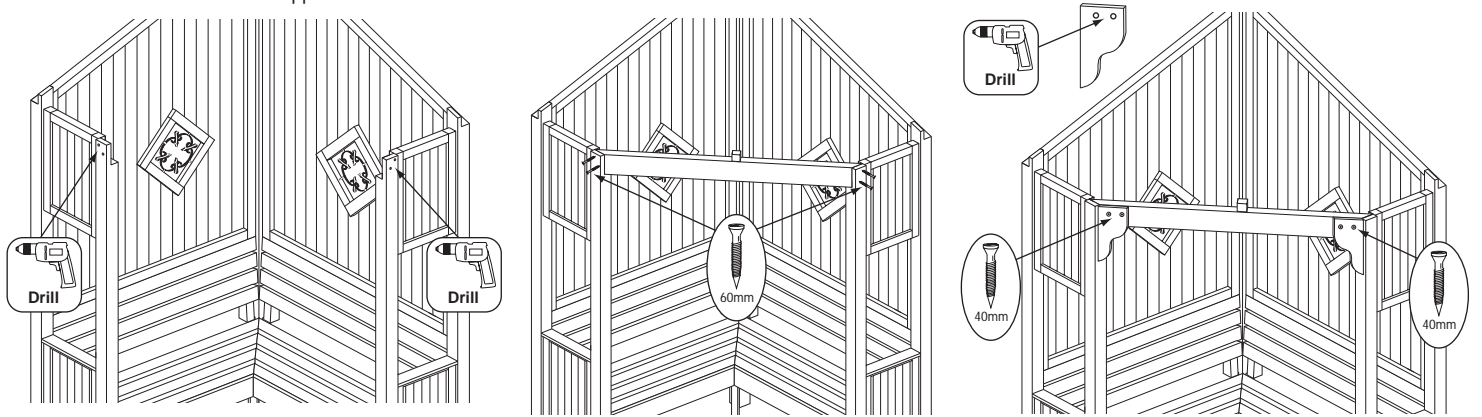

#### 6. Roof rafters

Drill 2 holes in each upright panel where indicated in the diagram below. Place the roof rafters on top of the back panels make sure the roof bearers face inwards as shown in the diagram, secure through the drilled holes of the upright into the roof rafters using 2 x 60mm screws per rafter.

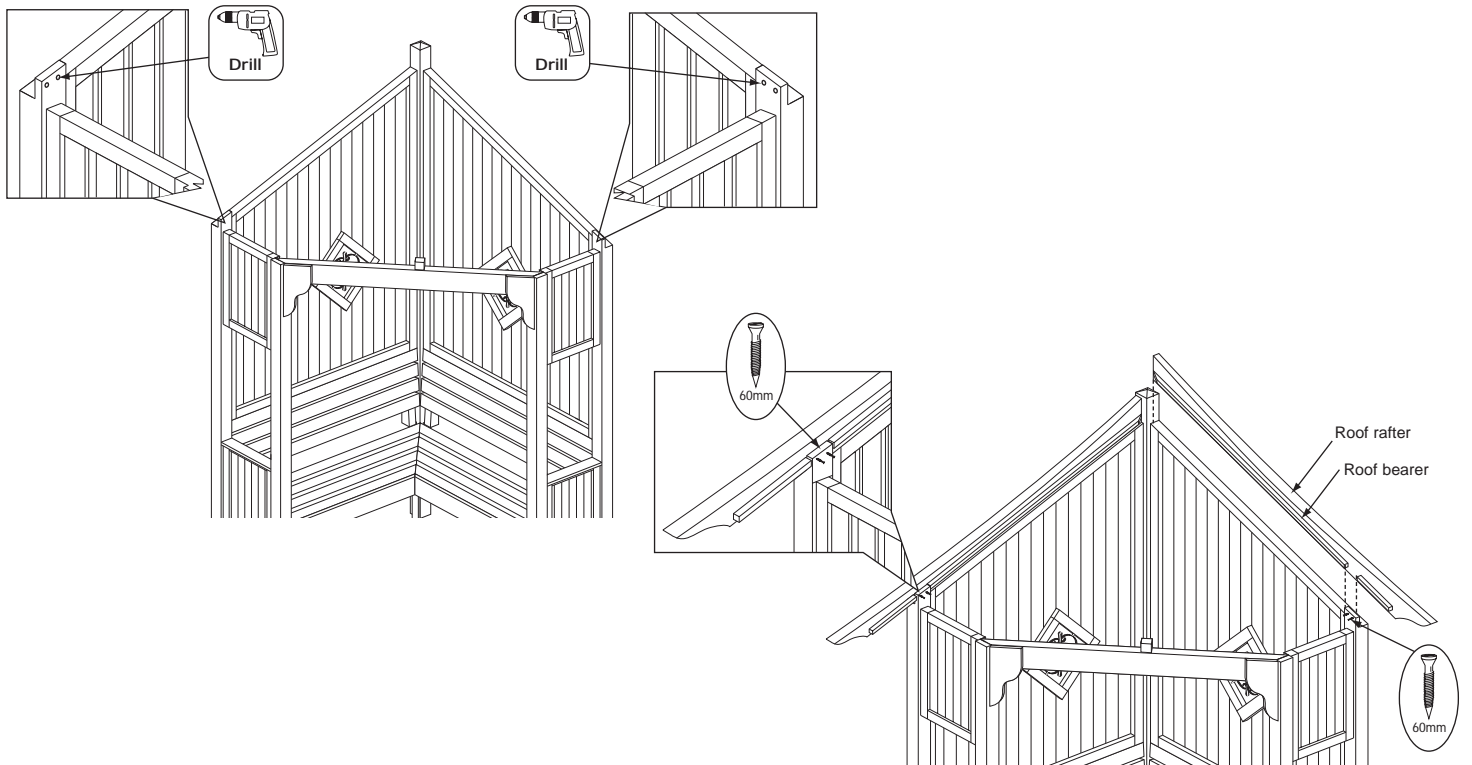

## 7. Centre roof rafter

Fix the centre roof support to the support block using 1 x 130mm screw as shown. Make sure that the back end of the centre roof rafter is touching the centre post and is at the same height as the outer roof rafters. Secure the outer rafters using 4 x 130mm screws through the holes in the centre post and into the ends of the roof rafters. Secure the centre rafter in the same way using 2 x 150mm screws.

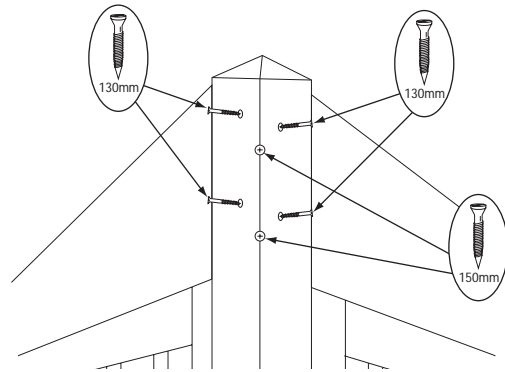
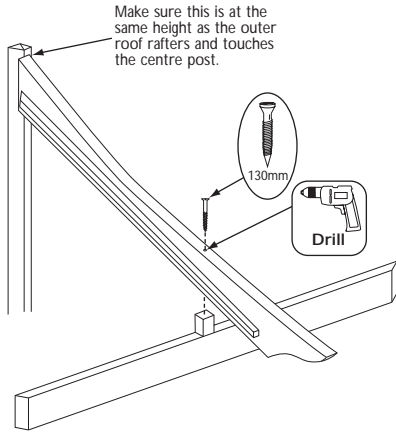

## 8. Roof panels

Lay the roof panels on the roof rafters and secure using 6 x 60mm screws per panel, screw through the panel and into the roof rafters as shown below.

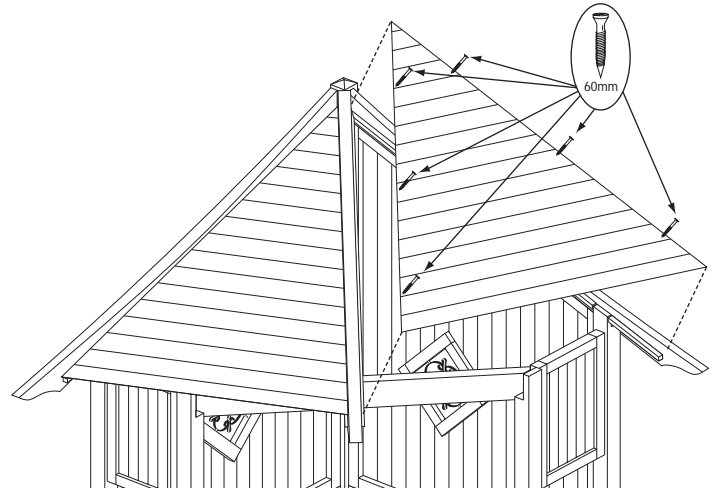
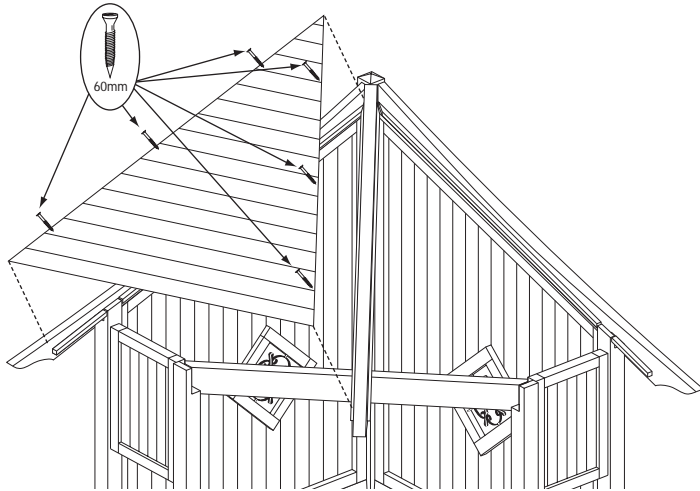

## 9. Coverstrips

Drill 4 holes in each top coverstrip as shown below. Lay cover strips in place and secure with 4 x 40mm screws per strip, screw through the drilled holes of the coverstrip into the roof panel. Fix the front coverstrips to the ends of the roof panel bearers with 3 x 40mm screws per coverstrip as shown.

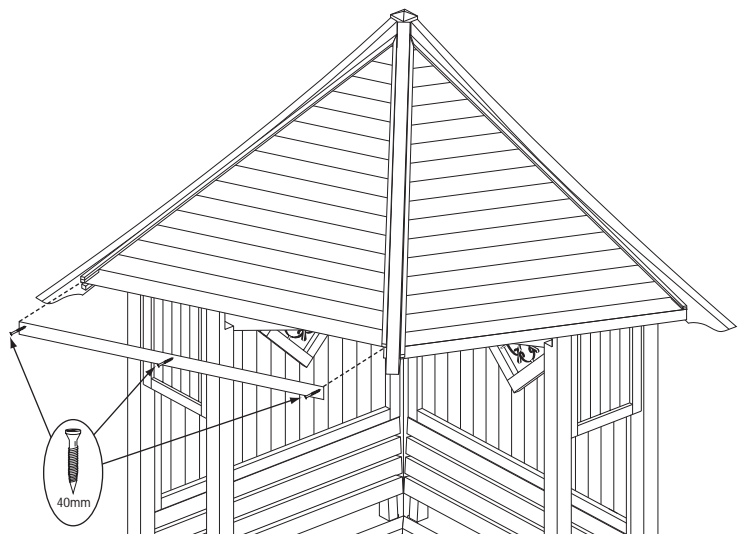
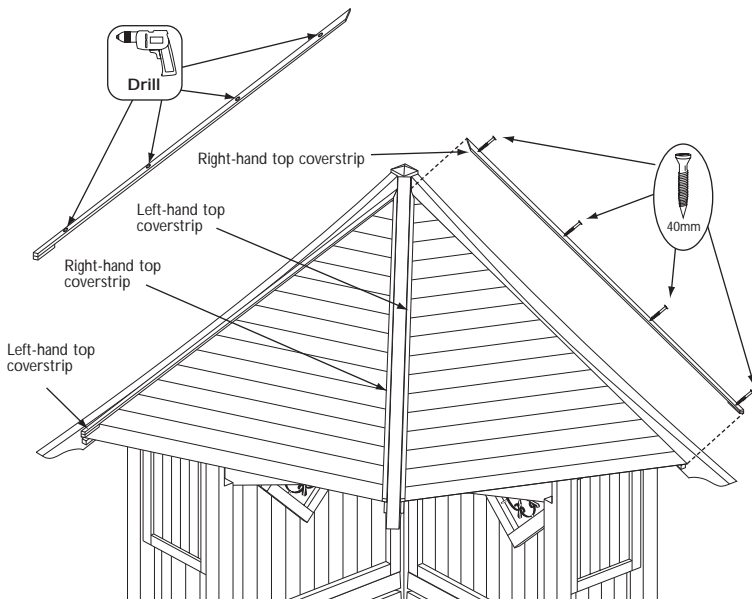

If in doubt of any aspect regarding the assembly, use or safety of your swing seat please contact us :

**Help Line (Normal Office Hours) 01829 261121**

ROWLINSON GARDEN PRODUCTS LIMITED  
Unit 2 Green Lane  
Wardle Nr.Nantwich  
Cheshire  
CW5 6BN  
Tel : 01829 262080  
Fax : 01829 262089

We constantly improve the quality of our products, occasionally the components may differ from the components shown and are only correct at time of printing. We reserve the right to change the specification of our products without prior notice.

2006 © Rowlinson Garden Products Ltd