

Ref 505614

Vers.1.1

Bûcher Colombus XXL

3600x800x1700 mm

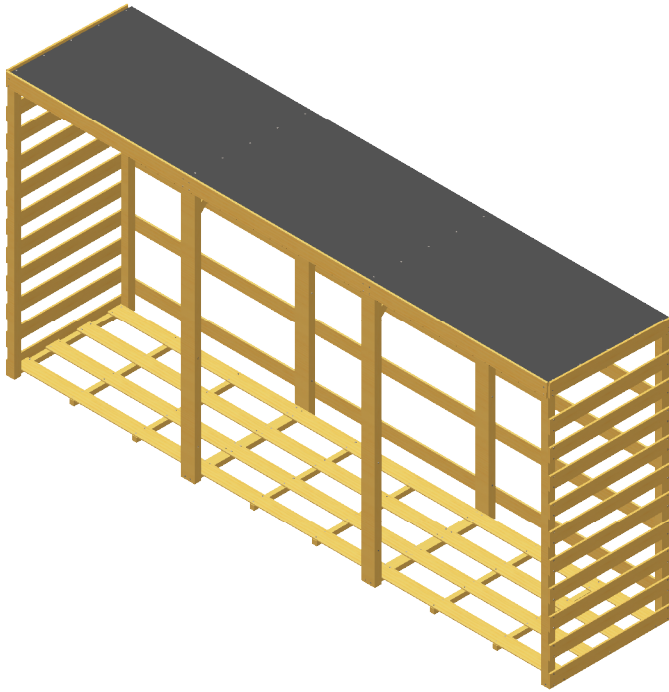

Cerland
ENJOY YOUR GARDEN

Français

Traitement

Pour assurer la pérennité du bois en extérieur, nous traitons nos produits en autoclave. Ce procédé d'imprégnation du bois par vide et pression permet d'avoir un traitement du bois par des agents conservateurs non toxiques. Ce traitement permet au produit d'être protégé contre les insectes, les pourritures, les champignons et les termites dans les conditions d'utilisations de sa classe (III ou IV).

Entretien

Le bois est un matériau naturel vivant, dont les dimensions, aspects, masses, formes et teintes peuvent évoluer, sans modifier les propriétés ni la fonctionnalité et la qualité du produit. Le bois subit un processus de grisaillement naturel au fil du temps qui nécessite un entretien régulier.



Entretien à l'eau 1 fois/an contre les éventuelles traces de mousse.



Possibilité de raviver la couleur avec un dégriseur et d'appliquer 2 nouvelles couches de lasure aqueuse 1 fois/an sur les produits lasurés.

English

Treatment

To ensure the sustainability of wood outdoors, we treat our product with autoclave process. This impregnation process of wood by pressure and vacuum allows a wood treatment by non-toxic preservatives. This treatment allows the product to be protected against insects, rot, fungi and termites in the conditions of its class of uses (III or IV)

Maintenance

Wood is a living natural material, the dimensions, aspects, weights, shapes and colors may change without changing the properties or functionality and quality of the product. Wood suffered a natural greyish tinge over time which requires maintenance.



Maintenance with water 1time/year against any traces of foam.



Possibility to revive the color with dégriseur and apply 2 new aqueous glaze layers 1time/year on the product.

Deutsch

Imprägnierung

Damit das Holz besser vor Witterungseinflüssen geschützt ist, behandeln wir unsere Produkte mit dem Kesseldruckimprägnier-Verfahren (KDI). Der Prozess der Imprägnierung mit Druck und Vakuum ermöglicht eine Behandlung des Holzes mit nicht-toxischen Mitteln. Dieses Verfahren schützt das Holz vor Insekten, Schimmel und Termiten. Die Intensität des Schutzes richtet sich nach der erzielten Gebrauchsklasse (III oder IV).

Pflege

Holz ist ein natürlicher und aktiver Rohstoff, dessen Abmessungen, Aussehen, Gewicht, Form und Farbton sich je nach der Holzart, aus der der Rohstoff gewonnen wurde, verändern können. Aufgrund von Oxidationsprozessen tendiert Holz zum Grauwerden. Um dies zu vermeiden, sollte das Holz regelmäßig gepflegt werden.



Jährliche Reinigung mit Wasser zur Vermeidung von möglicher Moosbildung empfehlenswert.



Es ist möglich, die ursprüngliche Farbe mit einem Entgrauer zurück zu bekommen. Tragen Sie zum verbesserten Schutz einmal jährlich 2 Schichten wasserlösliche Lasur auf.

Español

Tratamiento

Para asegurar la sostenibilidad de la madera de exterior tratamos nuestros productos con el proceso autoclave. En este proceso de impregnación de la madera a presión y vacío, la madera se trata con componentes no tóxicos. Este tratamiento protege el producto contra insectos, putrefacción, hongos y termitas en las condiciones de uso según las clases III o IV.

Mantenimiento

La madera es una materia natural viva; sus dimensiones, aspecto, peso, forma y color pueden cambiar sin modificar las propiedades o funcionalidad y calidad del producto. Sin embargo, debido a que la madera fue sometida a un tratamiento de tinte verdoso, con el tiempo requerirá un mantenimiento.



Mantenimiento con agua 1 vez/año. Evitar restos de espuma.



Se puede revitalizar el color y aplicar 2 capas de esmalte 1 vez/año.

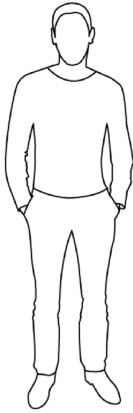
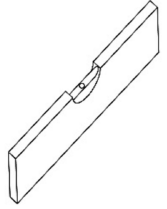
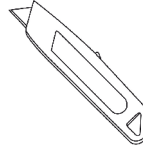
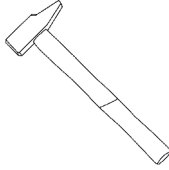

x2



05:00

Blister ref : S06438

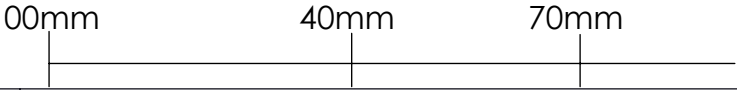

I		$\phi 4 \times 40$	x410
II		$\phi 4 \times 70$	x42
III		$\phi 3 \times 40$	x20

Pré-perçage / Pre-drilling / Vorbohren / Perforacion previa

ϕ Vis / ϕ Screw / ϕ schraube / ϕ Tornillo	ϕ Percage/ ϕ Drilling / ϕ Bohrung/ ϕ Perforacion
$\phi 4$ (I & II)	$\phi 3$

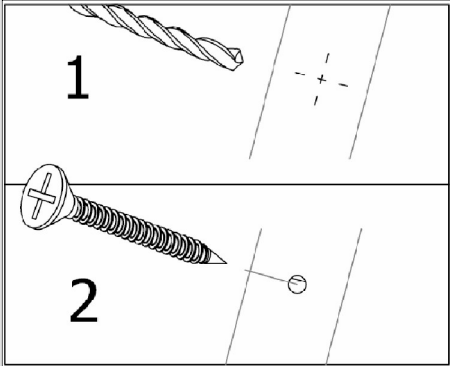

A
S56444

L=700 mm

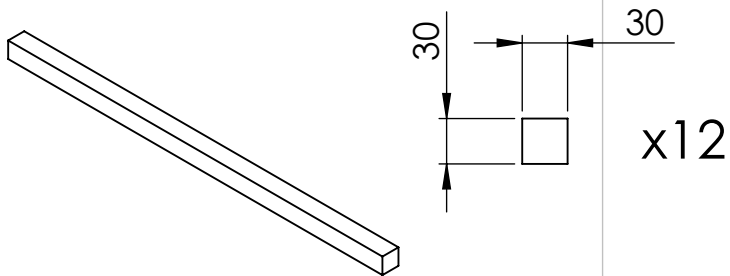

B
S56445

L=1180 mm

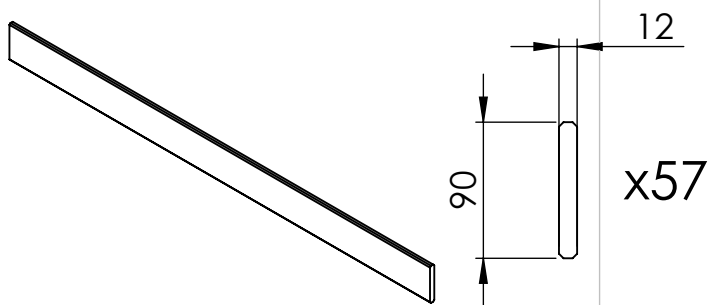

C
S56452

L=875 mm

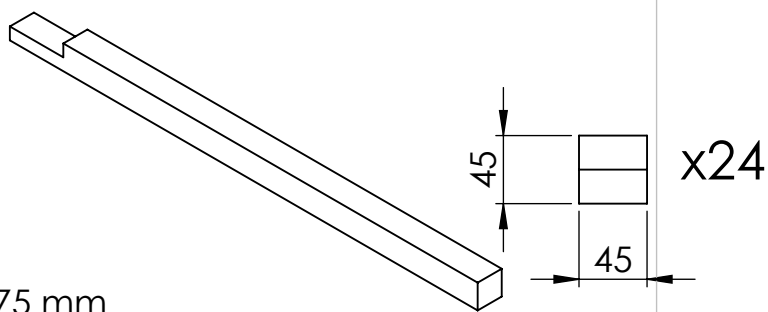

D
S56446

L=790 mm

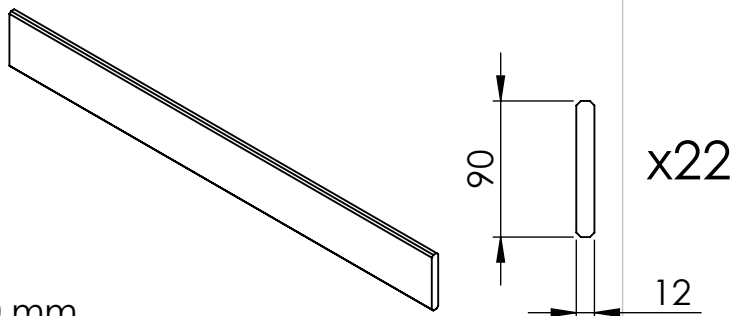

E
S56447

L=790 mm

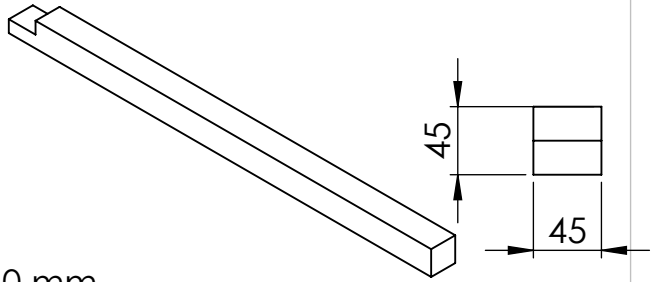

x6

F
S06450

1000x3600 mm



x1

G
S56453

L=790 mm

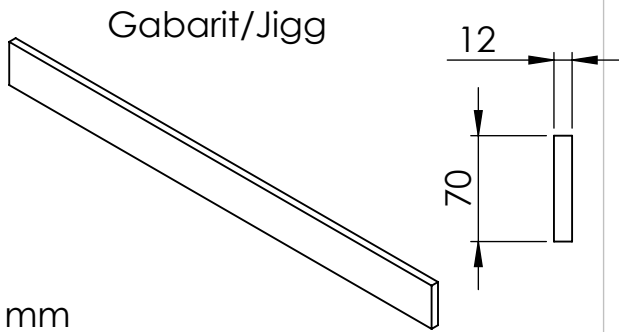

x1

H
S56451

L=250 mm

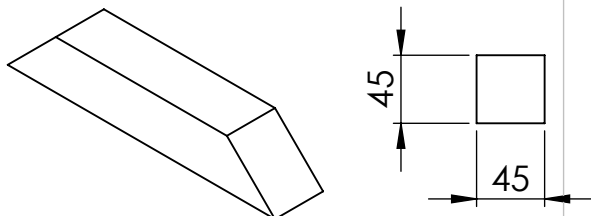

x4

First step | Première étape

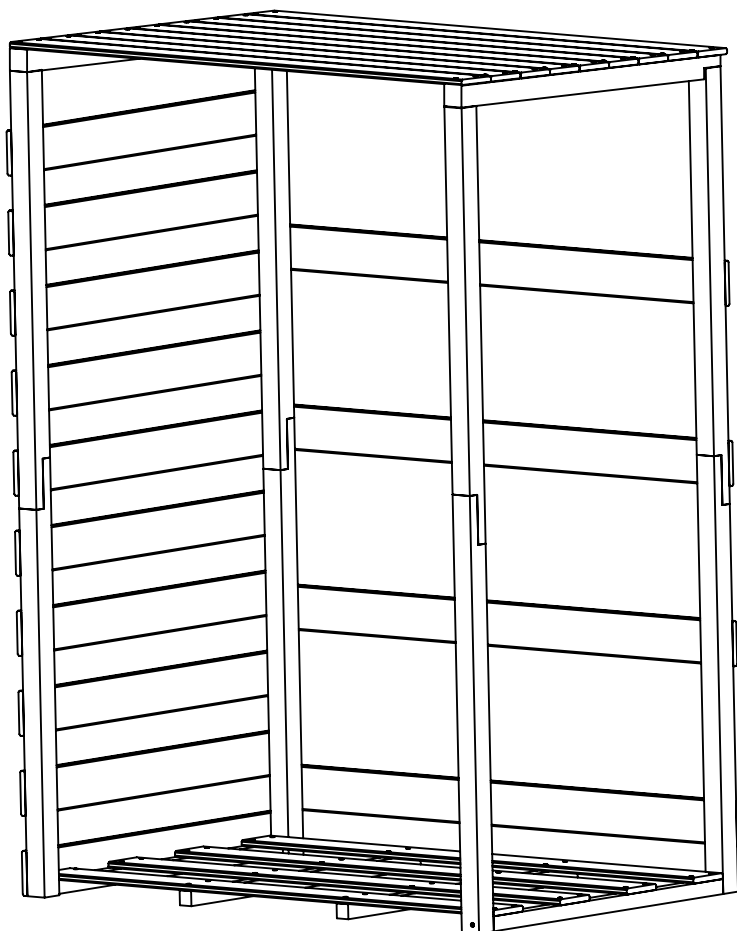

1/7

x4

C (x8)
I (x8)

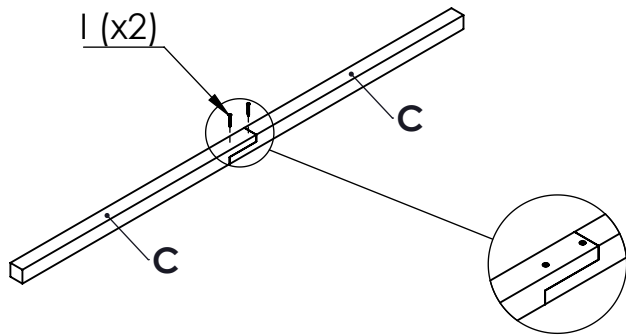

2/7

D (x10)
G (x1)
I (x40)

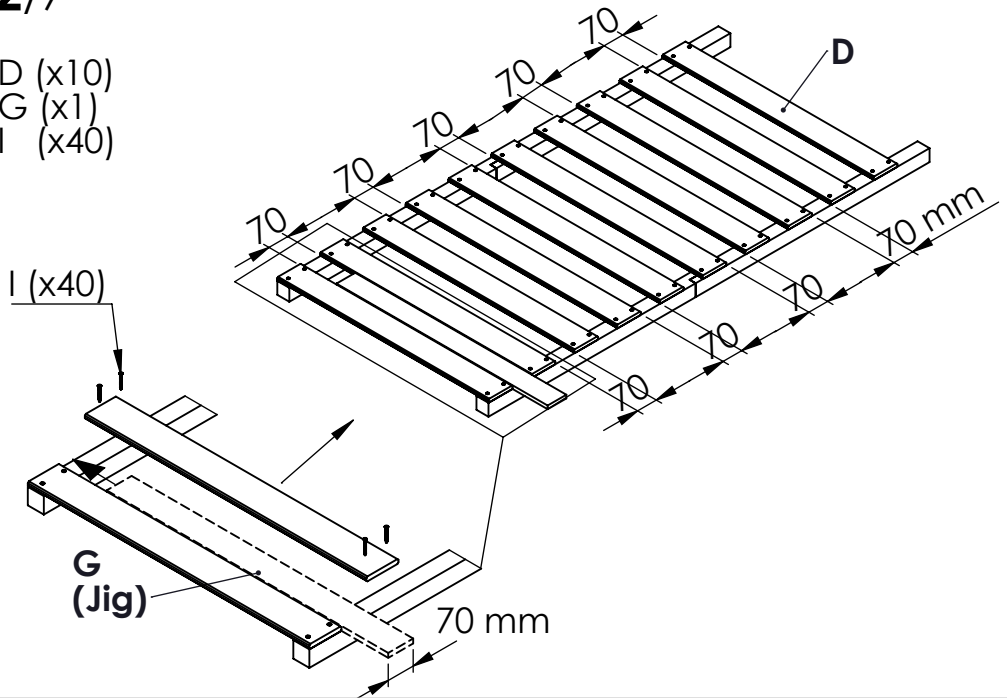

3/7

B (x4)
A (x4)
I (x32)

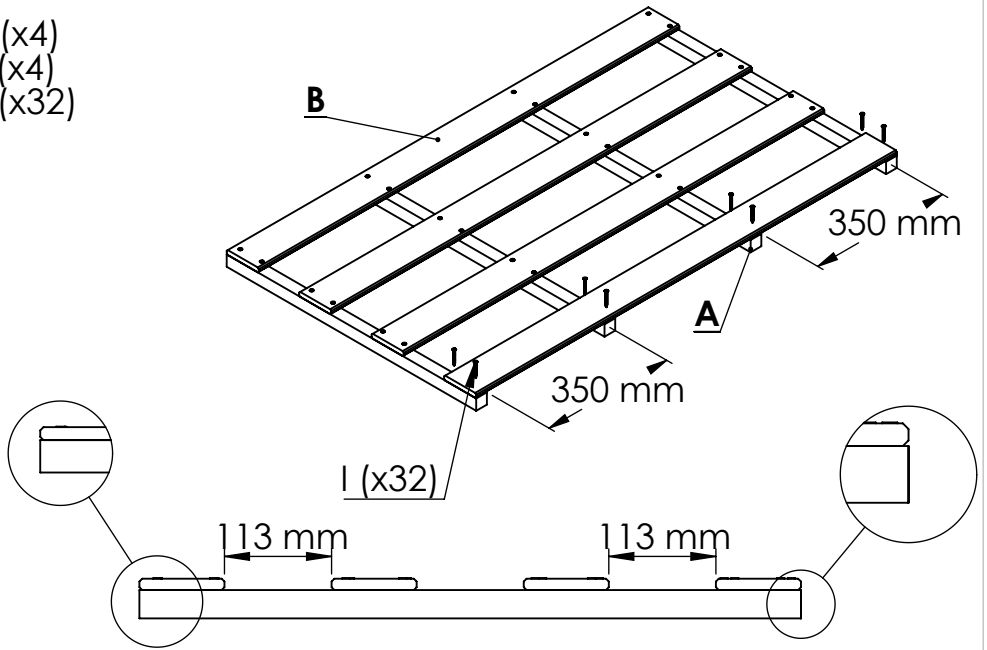

4/7

I (x3)

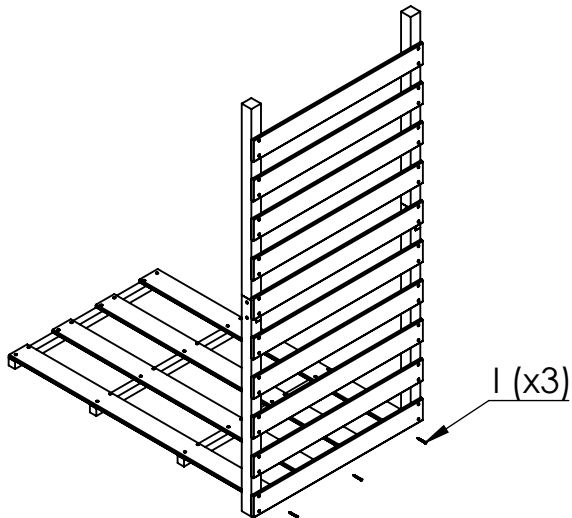

5/7

- E (x2)
- I (x2)
- II (x4)

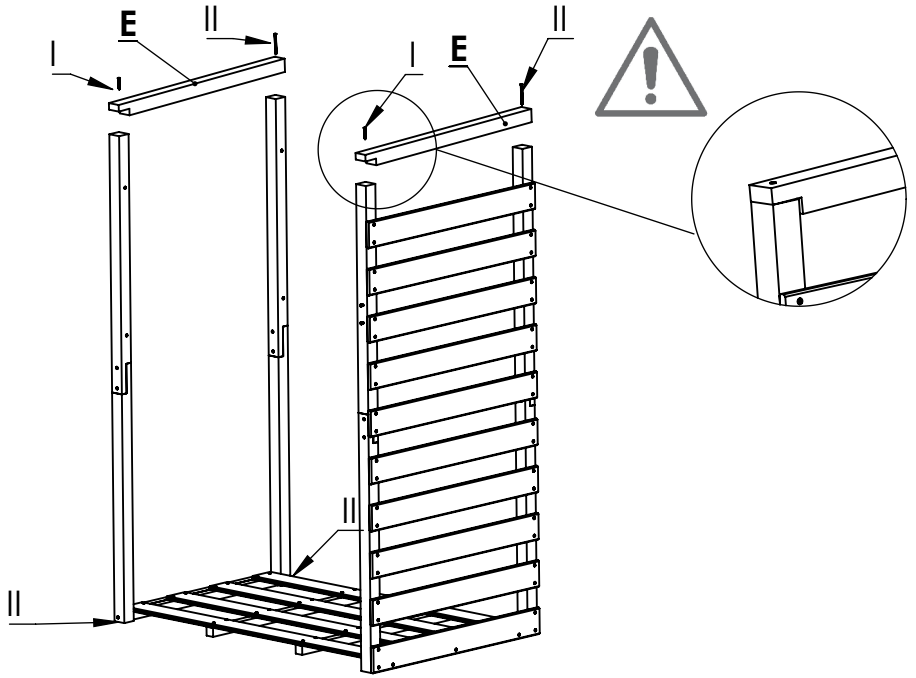

6/7

- B (x4)
- I (x16)

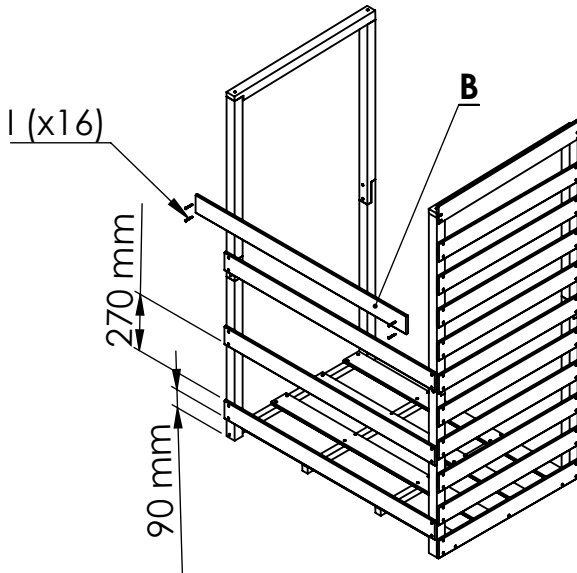

7/7

B (x9)
I (x36)

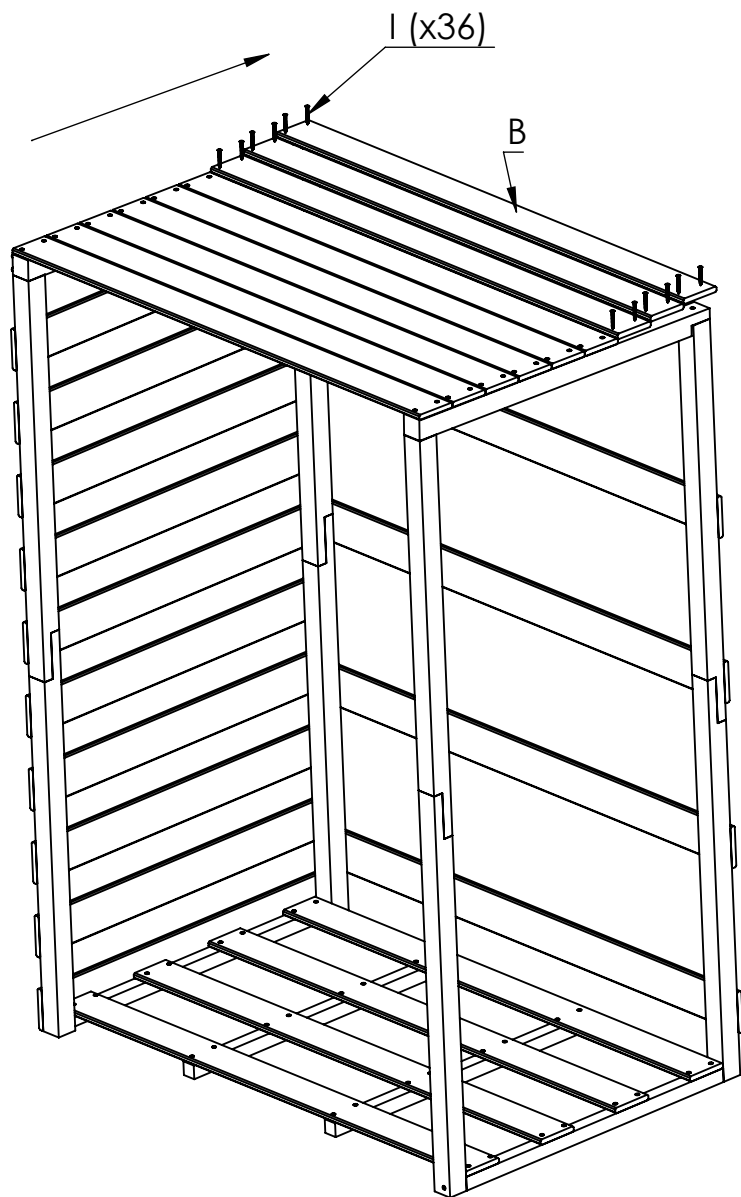

1/7

x4

C (x8)
I (x8)

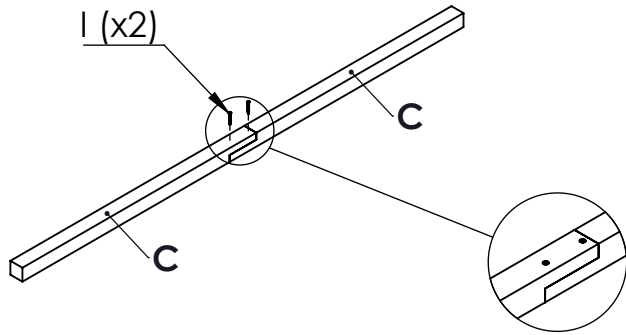

2/7

D (x10)
G (x1)
I (x40)

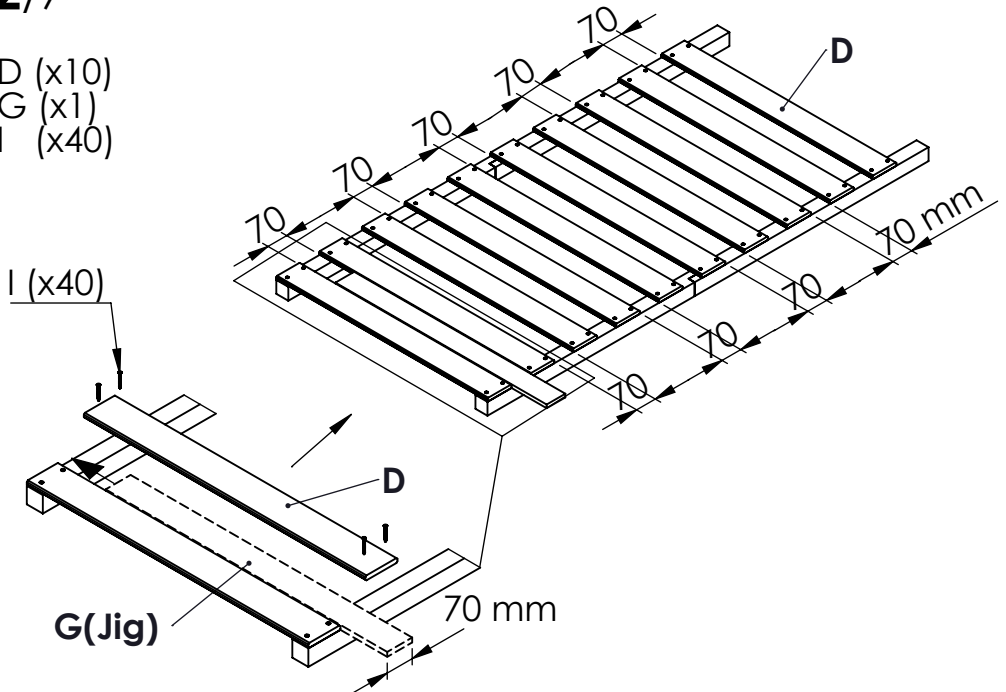

3/7

B (x4)
A (x4)
I (x32)

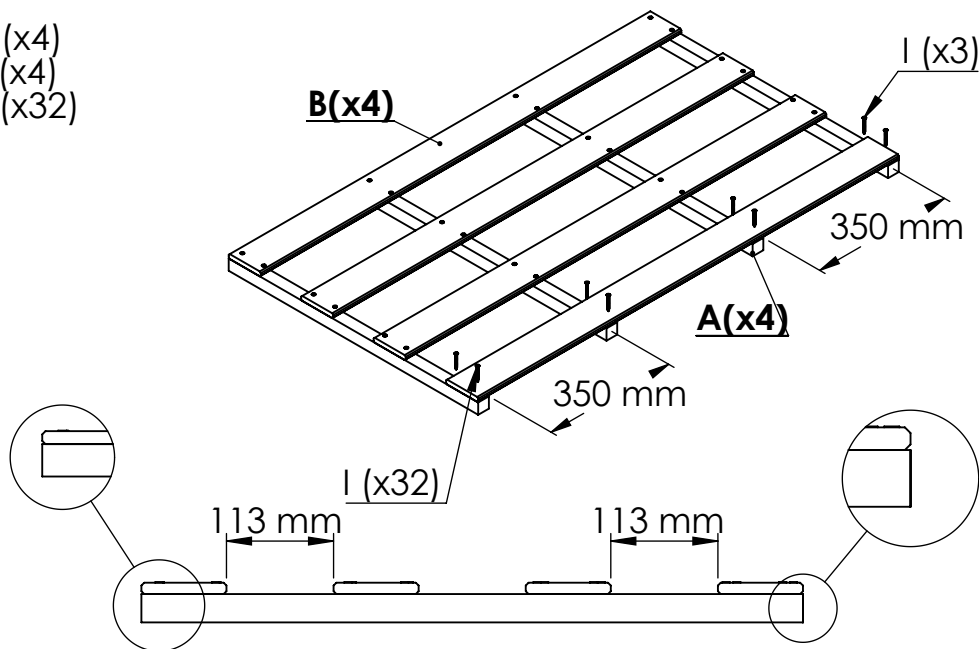

4/7

I (x3)

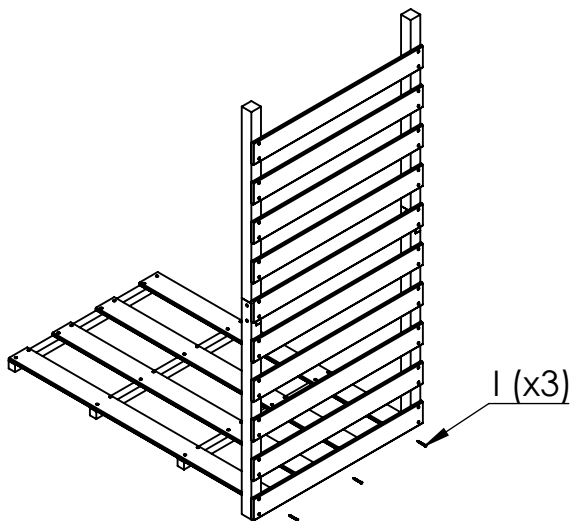

5/7

E (x2)
I (x2)
II (x4)

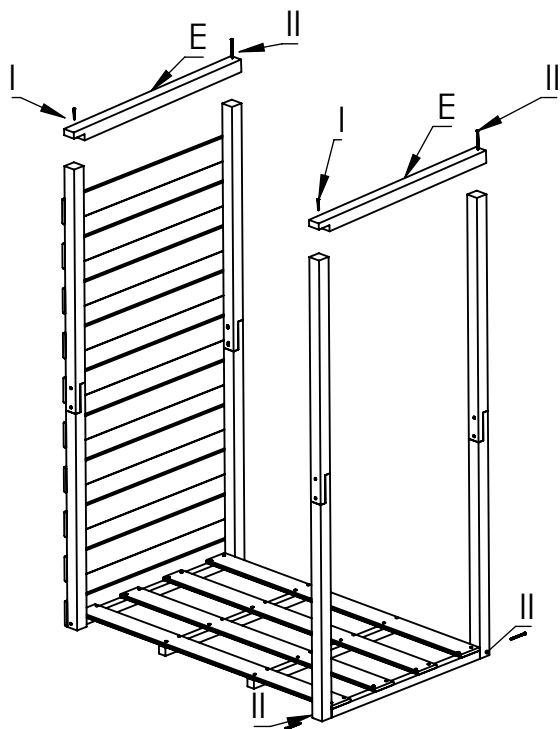

6/7

B (x4)
I (x16)

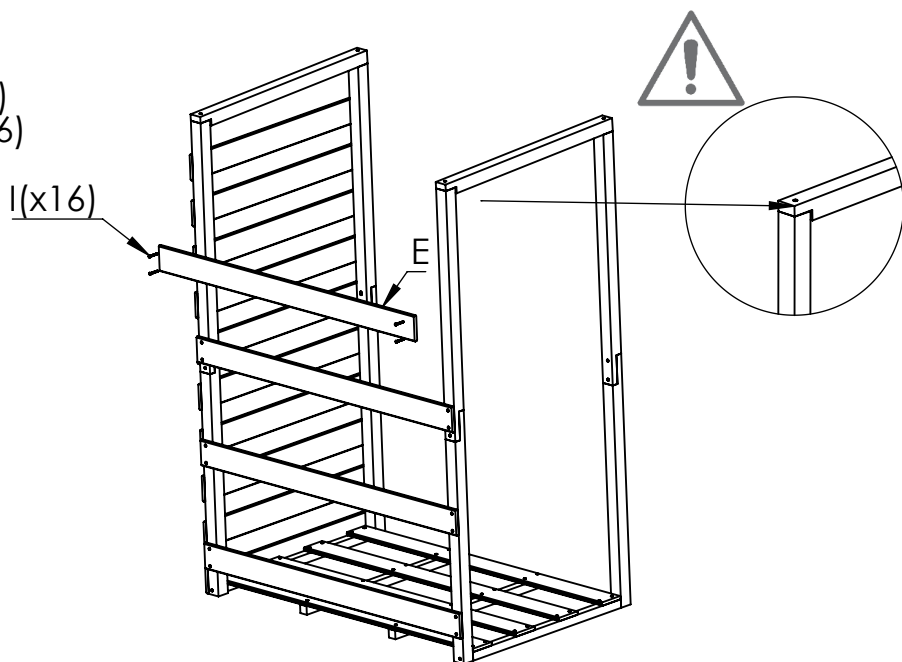

7/7

B (x9)
I (x36)

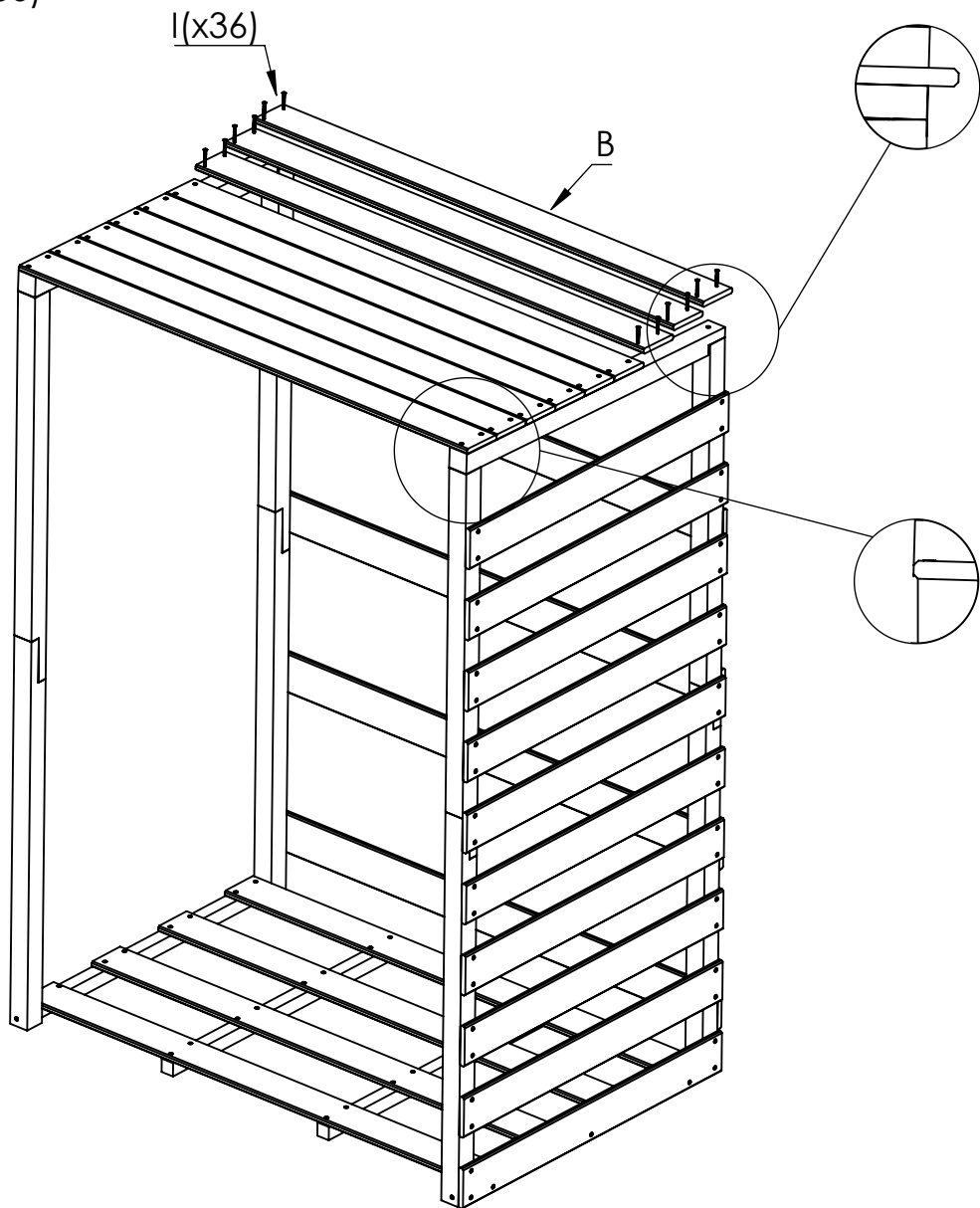

Third Step | Troisième Etape

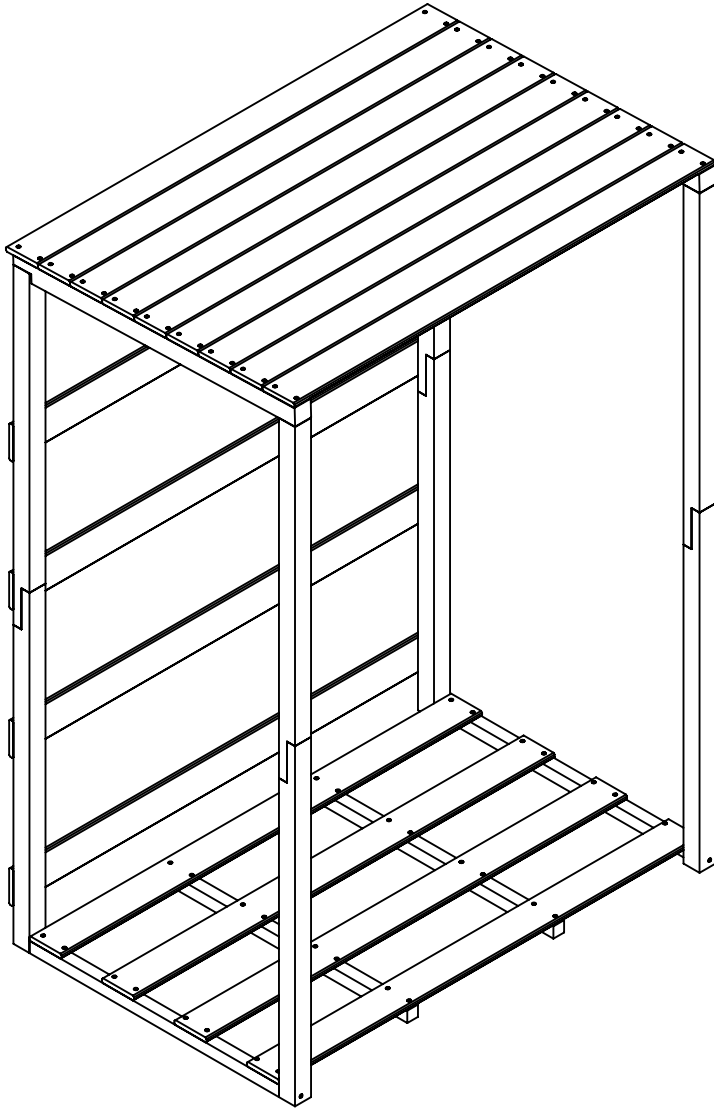

1/6

x4

C (x8)
I (x8)

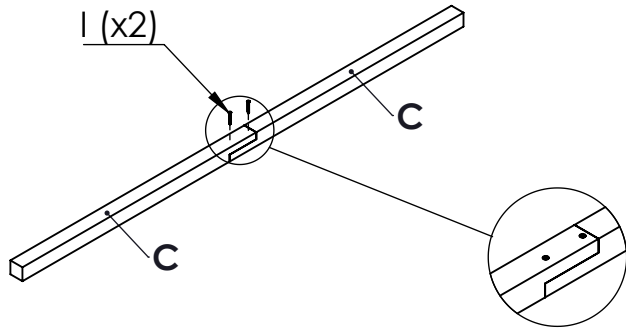

2/6

B (x4)
A (x4)
I (x32)

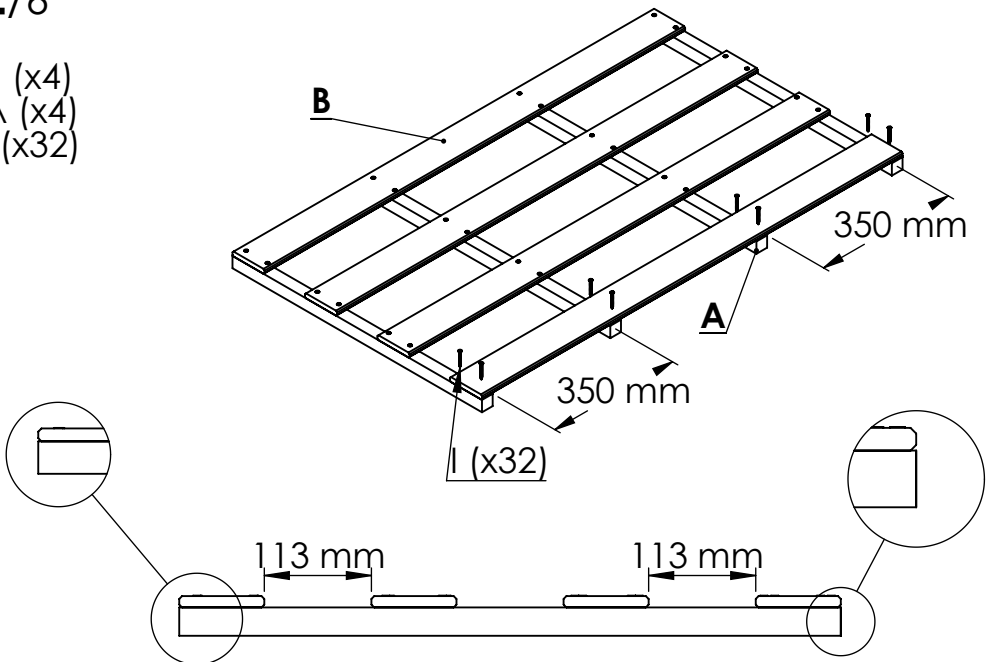

6/6

B(x9)
I(x36)

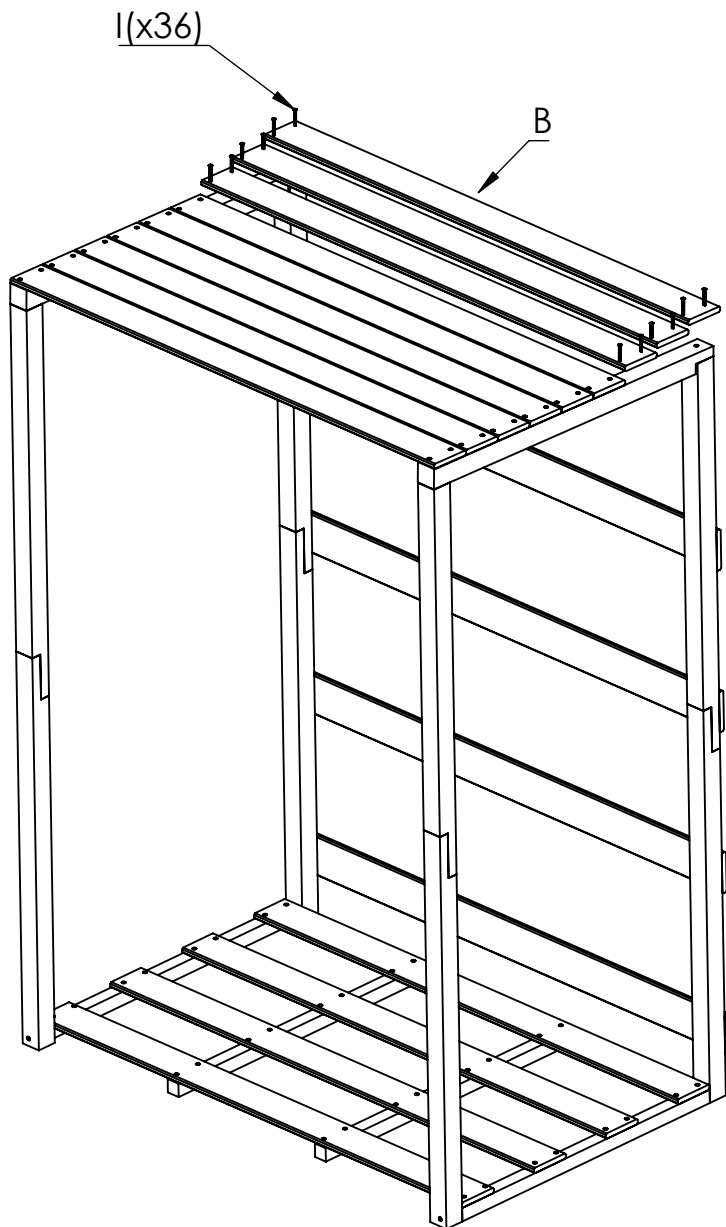

Fourth step | Quatrième étape

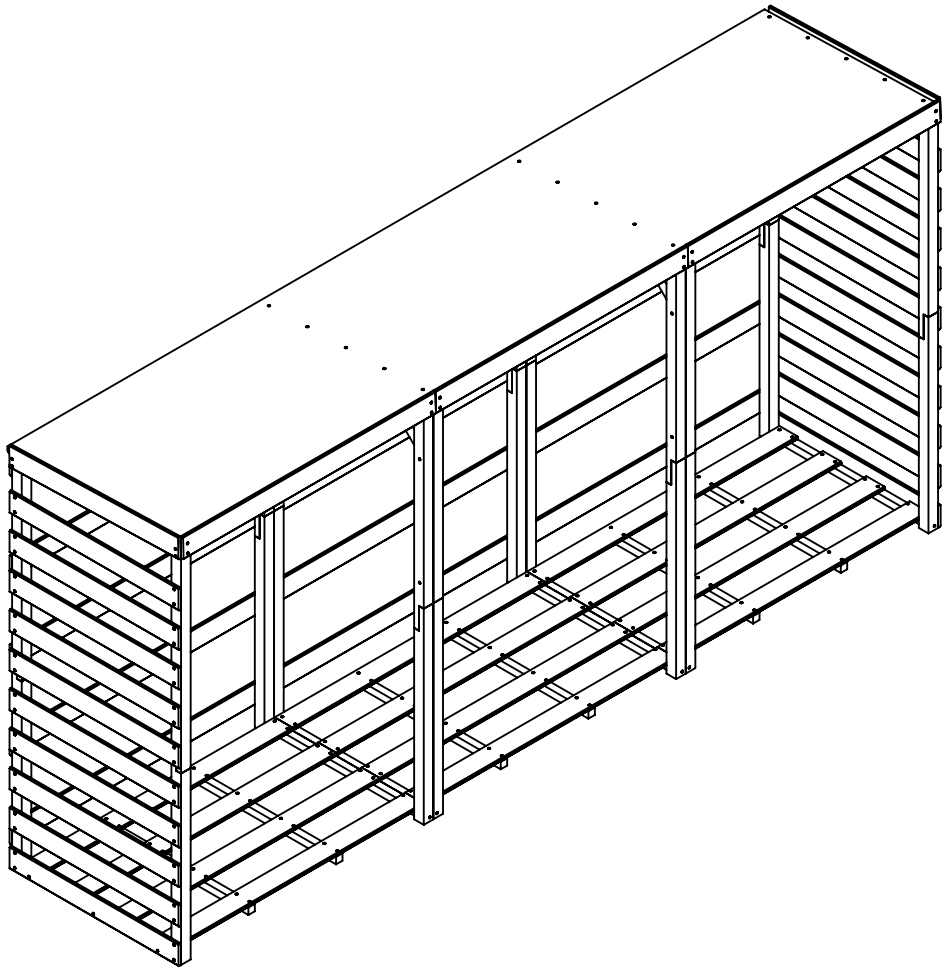

1/4

II (x16)

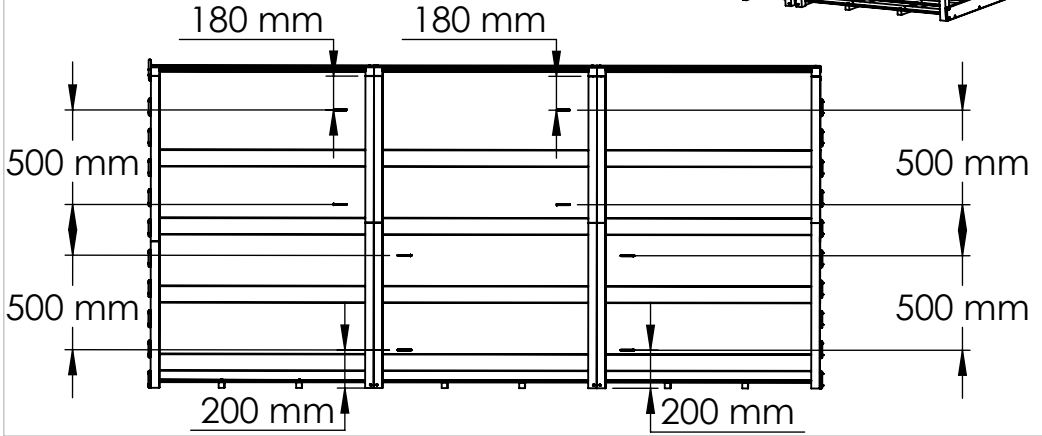
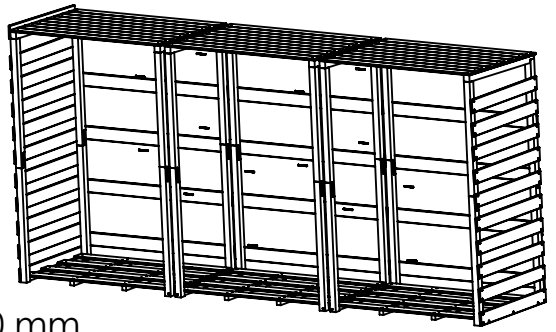

2/4

H (x4)
II (x8)

30 mm

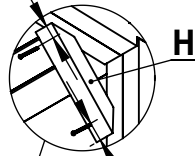

30 mm

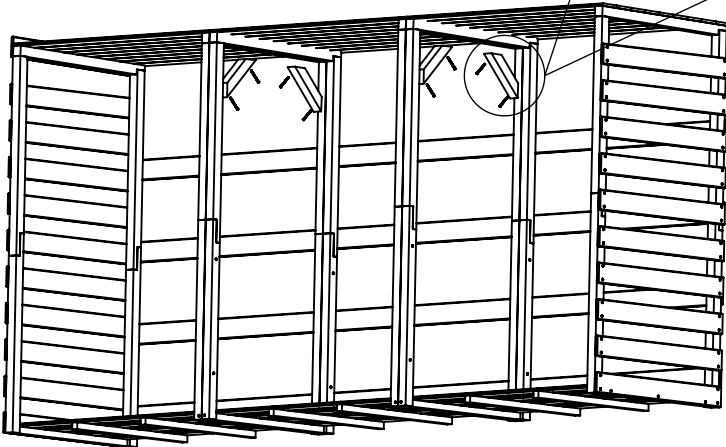
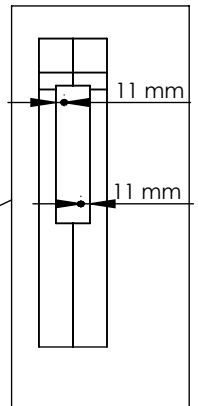

3/4

F (x1)
III (x20)

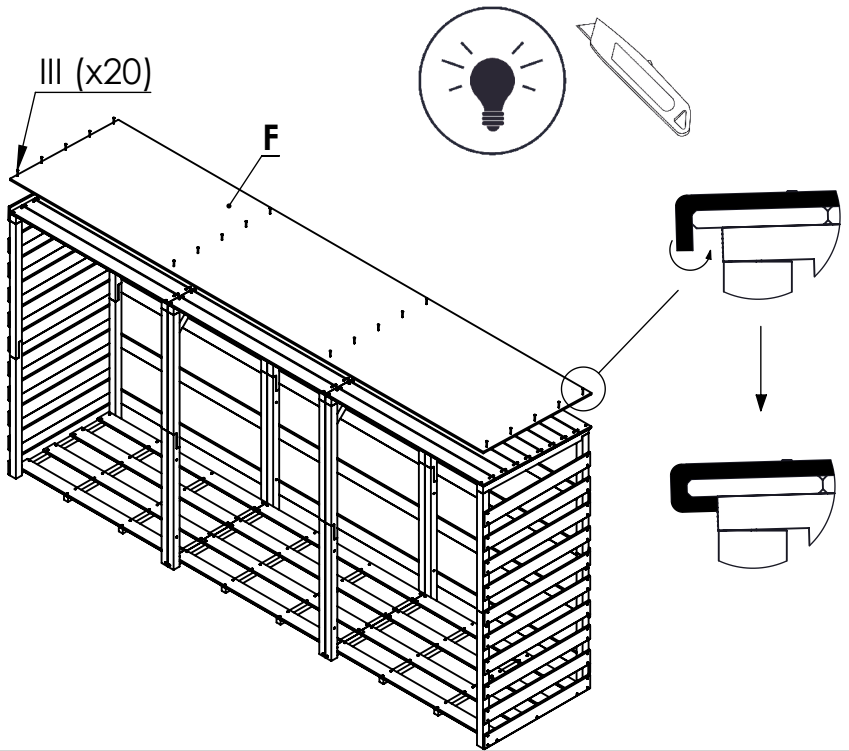

4/4

B (x6)
D (x2)
I (x32)

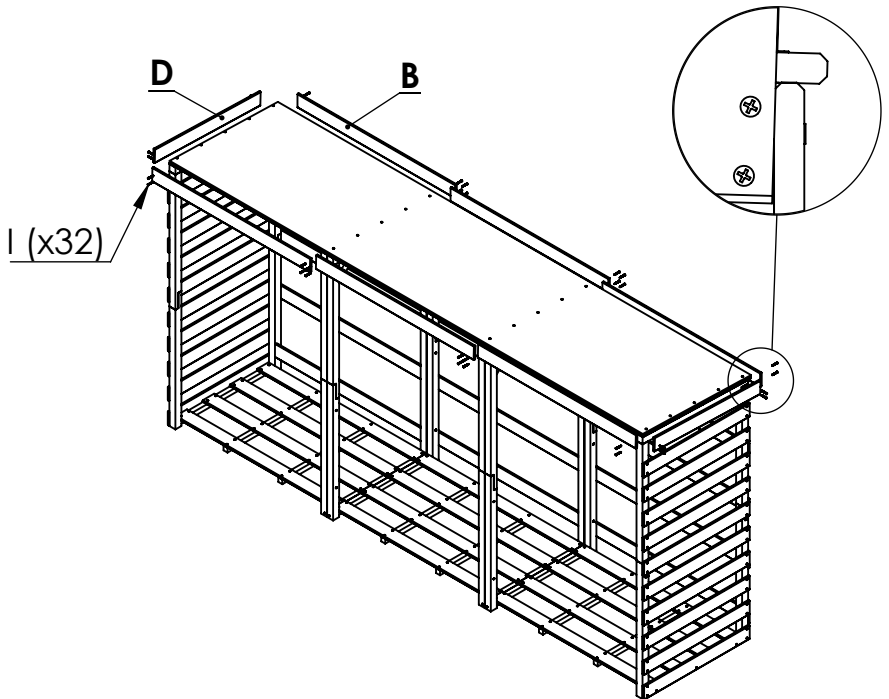

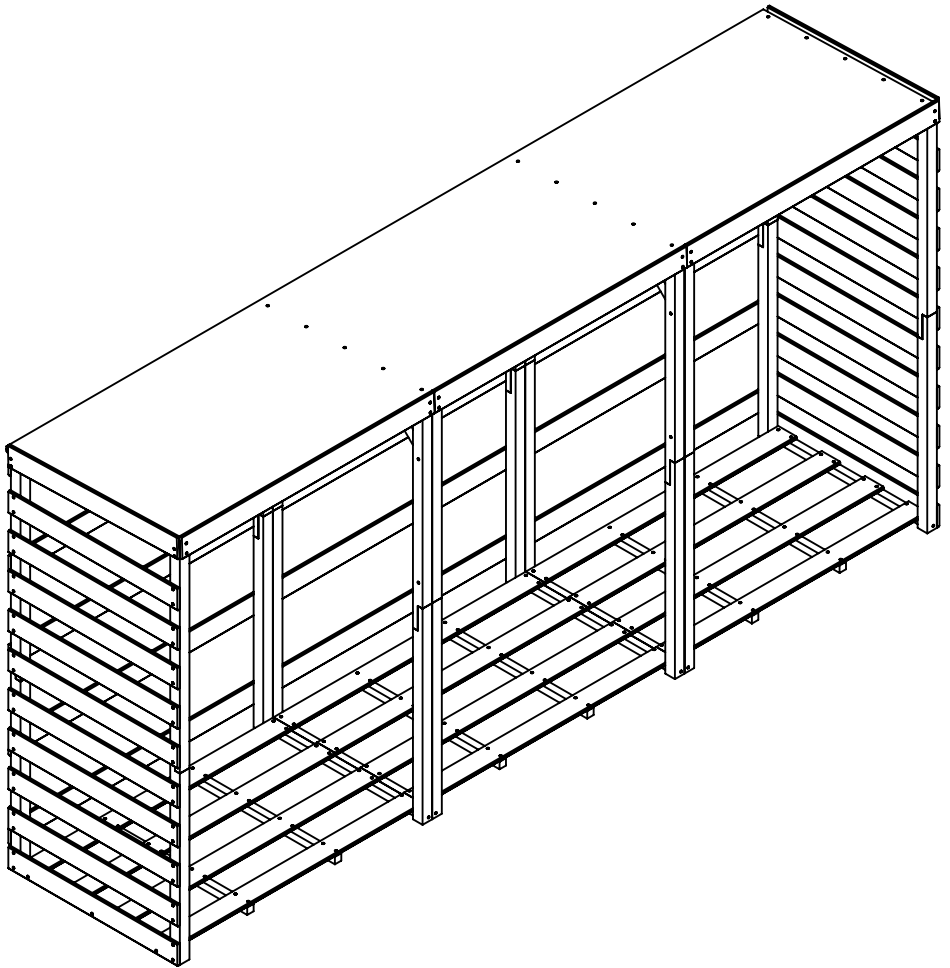



Cerland

ENJOY YOUR GARDEN